



SAN ANTONIO  
**ALAMODOME**

---

**TECHNICAL SPECIFICATION  
PACKET**



**100 MONTANA ST. SAN ANTONIO, TEXAS 78203**



## Table of Contents

<b>Facility Overview</b> .....	03
<b>Staff Directory</b> .....	04
<b>About San Antonio</b> .....	06
<b>Building</b> .....	08
Configurations .....	09
Locker Rooms, Backstage Rooms, Meeting Rooms.....	15
Press Box & Coaches/Broadcast Booths.....	17
Suites.....	18
Hospitality Spaces .....	19
Parking.....	21
Load In/Out.....	22
<b>Production</b> .....	24
A/V Specs .....	25
Ribbon Board Layout.....	26
A/V Equipment & Personnel.....	28
Power Map.....	30
Rigging and Load Capacities .....	31
Roof Grid & Catwalk .....	32
Existing Triax.....	34
Fiber Boxes .....	39
Fire Safety Requirements .....	57
Permitting.....	58
Current Equipment & Labor Rates .....	59

# FACILITY OVERVIEW



## The Alamodome

Opened in 1993, the Alamodome has consistently cast its spotlights on an incredible range of entertainment and sporting events. The Alamodome is a versatile facility with over 160,000 square feet of flexible space, hosting an average of 150 events per year. The Alamodome is a city-owned and operated multipurpose facility located in the heart of downtown San Antonio.

### Architect:

Populous  
Marmon Mok  
W.E. Simpson Company

### General Contractor:

Huber, Hunt & Nichols

### Owner & Operator:

City Of San Antonio

### Tenants:

San Antonio Sports  
UTSA Roadrunners Football  
Valero Alamo Bowl



# STAFF DIRECTORY

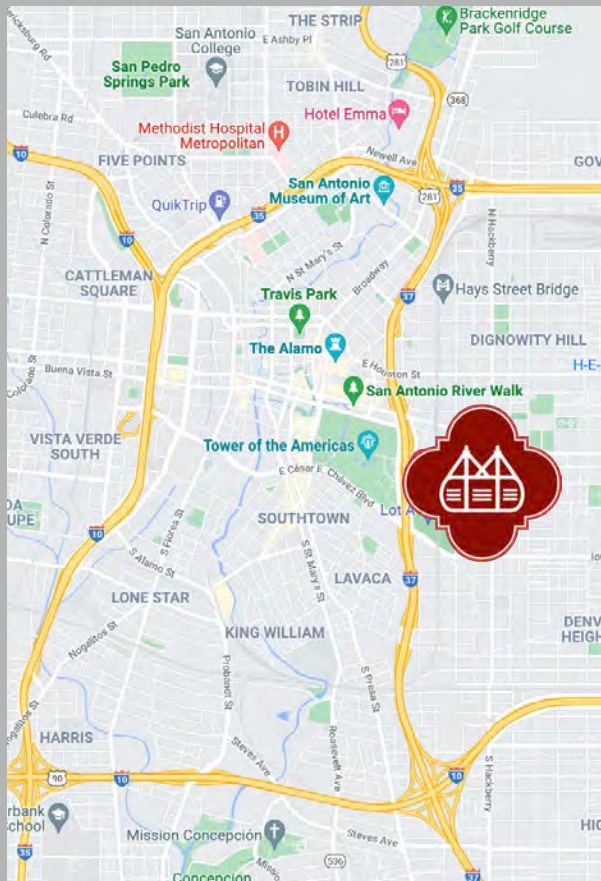

## Address

**100 Montana Street  
San Antonio, TX 78203**

## Main Switchboard

**210.207.3663**

## Main Fax Number

**210.207.3646 (DOME)**

## 24/7 Alamodome Public Safety

**210.207.3680**

## Website

**Alamodome.com**

## Social Media

**Facebook.com/Alamodome**

**Twitter: @Alamodome**

**Instagram: @AlamodomeSA**

## Administration

Stephen Zito, Assistant Director, CSEF/Alamodome  
Stephen.Zito@sanantonio.gov | 210.207.3605

## Business and Finance

Michael Flores, General Manager  
Michael.Flores@sanantonio.gov | 210.207.3620

Javier Tamez, Business Manager  
Javier.Tamez2@sanantonio.gov | 210.207.3650

Denise Reyes, Administrative Assistant II  
Denise.Reyes@sanantonio.gov | 210.704.6330

## Box Office

Amanda Yruegas, Box Office Manager  
Amanda.Yruegas@sanantonio.gov | 210.207.3609

Rozanna Santos, Box Office Supervisor  
Rozanna.Santos@sanantonio.gov | 210.207.3635

## Event Services

Paula Hobbie, Event Services Manager  
Paula.Hobbie@sanantonio.gov | 210.207.3671

Edward Miranda, Senior Events Coordinator  
Edward.Miranda@sanantonio.gov | 210.207.3636

Andrea Austin-Thomas, Senior Event Coordinator  
Andrea.Austin-Thomas@sanantonio.gov |  
210.207.3602

Alex Legg, Event Coordinator  
Alex.Legg@sanantonio.gov | 210.207.3642

## Food & Beverage Services

### Savor... Black Tie

Bea Gulow, Director of Food and Beverage  
bgulow@savorbt.com | 210.704.6363

Jennifer Casino, Premium Services Director  
jenniferc@savorbt.com | 210.704.6364

Eric Garcia, Suite Supervisor  
egarcia@savorbt.com | 210.906.7005

## **Guest Services**

Michelle Brady, Customer Service Representative  
Michelle.Brady@sanantonio.gov | 210.207.3607

## **Maintenance and Engineering**

Eric Duncan, Building Maintenance Manager  
Eric.Duncan@sanantonio.gov | 210.207.3608

Vincent Medina, HVAC Supervisor  
Venancio.Medina@sanantonio.gov | 210.207.3668

## **Operations**

Tom McAfee, Building Operations Manager  
Thomas.McAfee@sanantonio.gov | 210.207.3754

## **Parking Services**

Frank Anaya, Parking Manager  
Frank.Anaya@sanantonio.gov | 210.207.3753

## **Public Safety Services**

Troy Ragland, Public Safety Manager  
troy.ragland@sanantonio.gov | 210.207.3685

## **Event Guest & Security Services**

Richard Campbell, Branch Manager  
richard.a.campbell@aus.com | 210.704.6752

## **Fire Prevention Services**

SAFD Special Events Office | 210.207.3695

## **Law Enforcement Services**

SAPD Off-Duty Office | 210.207.7020

## **Sales and Marketing**

Toryn Jones, Sales and Marketing Administrator  
Toryn.Jones@sanantonio.gov | 210.207.3752

Victor Cabarello, Marketing Manager  
Victor.Cabarello@sanantonio.gov | 210.207.3691

Rick Garcia, Design Communications Coordinator  
Rick.Garcia@sanantonio.gov | 210.207.3626

Henry Jaime, Audio/Visual Production Coordinator  
Henry.Jaime@sanantonio.gov |

Lenzy Mora, Graphic Designer  
Lenzy.Mora@sanantonio.gov | 210.207.3682

## **Technical Services**

Jason Bippert, Telecommunications Manager  
Jason.Bippert@sanantonio.gov | 210.207.3629

Manuel Corales, Audio/Visual Production Supervisor  
Manuel.Corales@sanantonio.gov | 210.207.3640

# About San Antonio...

## Airport

Located in north central San Antonio, the San Antonio International Airport (SAT) is only 8.5 miles from the downtown business district - about a 15-minute drive - which is unusual for major metropolitan areas.

## Public Transportation

Getting around San Antonio and downtown is a breeze with our wide selection of transportation options, including the VIVA by VIA service, River Taxi, Cabs, Uber, and Lyft.

## Driving

### FROM IH-35 SOUTH

Take US-90 East to New Braunfels Street exit, north on New Braunfels to Commerce Street, west on Commerce Street to Cherry Street, south on Cherry Street and into lots.

### COMING FROM IH-10 EAST

Use Hackberry Street exit, north on Hackberry to Cesar Chavez Blvd., west on Cesar Chavez Blvd. to Cherry Street, North on Cherry Street and into lots.

### COMING FROM IH-10 WEST

Use IH-35 north to New Braunfels Street exit, south on New Braunfels to Commerce Street, West on Commerce Street to Cherry Street, south on Cherry Street and into lots.

### COMING FROM IH-37 SOUTH

Use Cesar Chavez Blvd. exit, east on Cesar Chavez Blvd. to Cherry Street, north on Cherry Street and into lots.

### COMING FROM US 281 NORTH

Use Cesar Chavez Blvd. exit, east on Cesar Chavez Blvd. to Cherry Street, north on Cherry Street and into lots.

## Hotels

With over 14,000 hotel rooms in downtown San Antonio there are endless lodging options within walking distance of the Alamodome. A Visit San Antonio representative can assist with all travel needs. See [VisitSanAntonio.com](http://VisitSanAntonio.com) for more information.

## Recreation/Attractions

Home to the legendary Alamo and world-famous River Walk, San Antonio offers a wide range of exciting and unique activities. San Antonio has five theme parks, working ranches, rivers to float, and 300 days of sunshine perfect for golfing one of our 50 courses. In San Antonio there is something for everyone.

## Dining

While San Antonio is famous for Tex-Mex, you'll also find traditional Mexican cuisine along with German, French, English and Italian eateries. The venues are just as varied as the types of cuisine they serve. From white tablecloth to savory food trucks to genuine steakhouses and BBQ joints, there's always something new and different to try.

## Shopping

According to [Forbes.com](http://Forbes.com), San Antonio is one of America's top ten best cities to shop. With several malls and local shops displaying handmade items, you can take home both the culture of San Antonio and the latest fashion trends.

## Hospitals

Multiple medical facilities are available within two miles of the Alamodome (Baptist Medical Center, The Children's Hospital of San Antonio), as well as a short six mile drive to a major medical complex of several hospitals with nationally recognized physicians and research facilities.

# SAN ANTONIO DOWNTOWN AREA



For more information on hotels, restaurants, events and sightseeing tours, come by the Official Visitor Information Center at 317 Alamo Plaza or call toll free 800-447-3372. Located directly across from the Alamo. OPEN SEVEN DAYS A WEEK (CLOSED: New Year's Day, April 24th – Battle of Flowers Parade, September 30th, Thanksgiving Day and Christmas Day).

VisitSanAntonio.com





# BUILDING

The Alamodome is a unique facility with the flexibility to host a wide variety of events. The following are examples of the more common configurations, however any plan can be adjusted to meet specific event needs.

## Capacities Per Configuration

**Full Stadium- Football & Soccer: 62,834**

**Full Stadium - South Stage: 56,016**

**Full Stadium - In The Round: 71,296**

**Full Stadium - Boxing In The Round: 68,830**

**Alamodome Theatre - 13,158**

**Modified Arena Boxing: 29,264**

**Arena Boxing: 35,562**

**Modified Arena Graduations: 29,476**

**Modified Arena South Stage: 30,648**

**Arena East Stage: 25,507**





# Full Stadium - South End Stage

\*The estimated capacity includes the typical number of floor seats (11,064) for this configuration. Capacities based on your needs may vary.

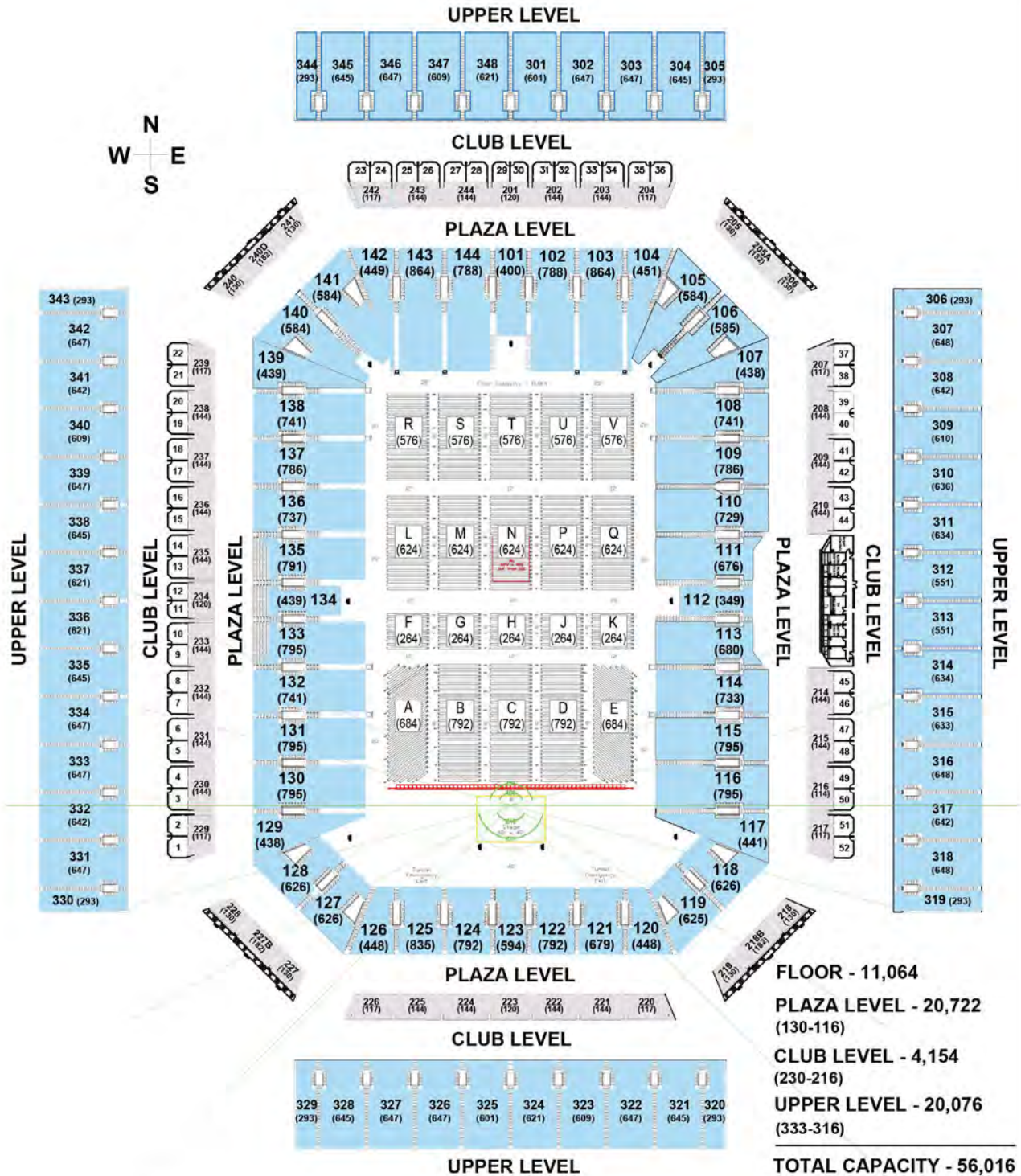

laskercadservices.com

Stadium  
South End Stage  
(56,016)



04/28/22



# Full Stadium - Boxing In The Round

\*The estimated capacity includes the typical number of floor seats (5,996) for this configuration. Capacities based on your needs may vary.

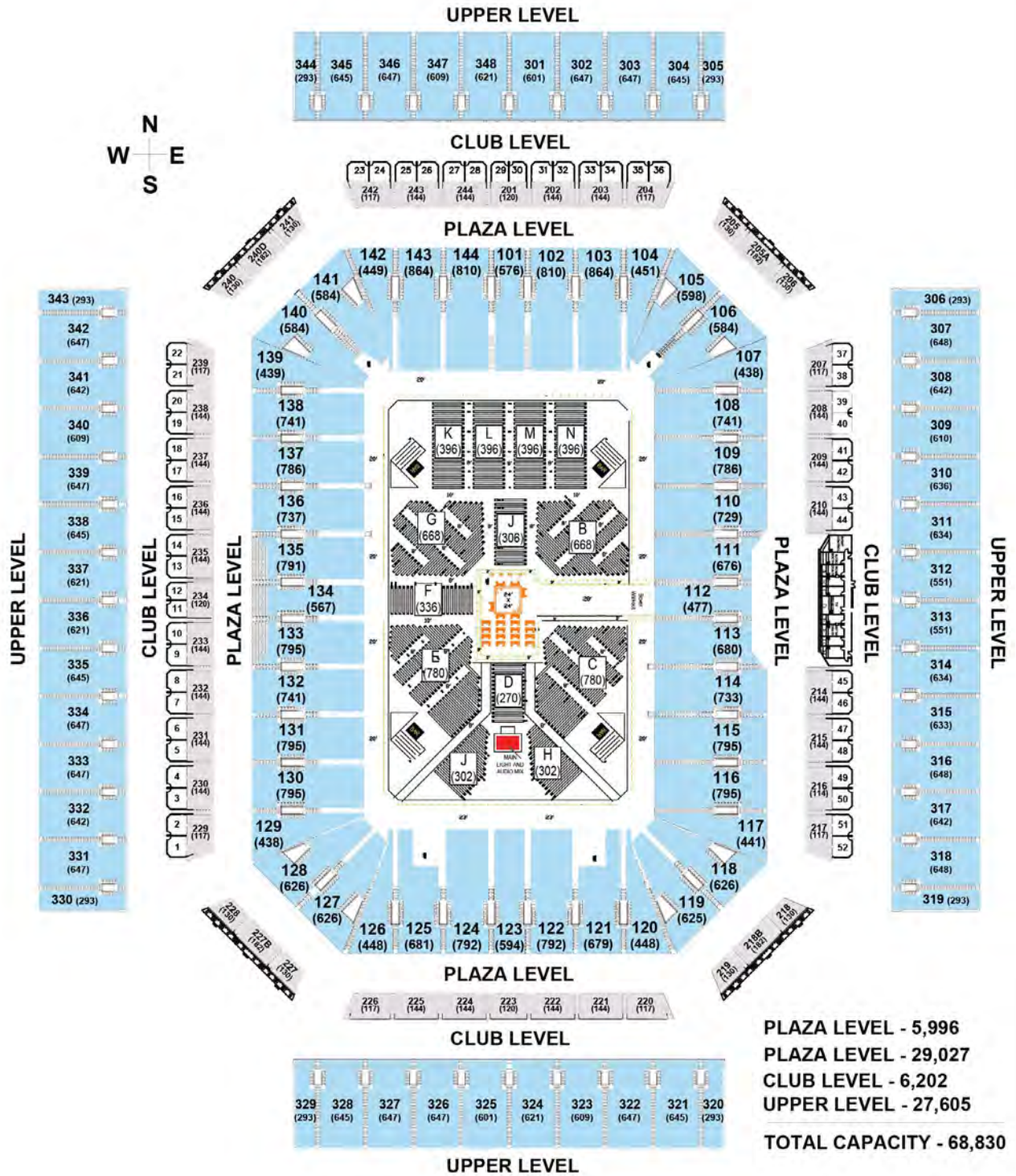

laskercadservices.com

Stadium  
Boxing In The Round  
(68,830)



02/23/22

# Alamodome Theatre

\*The estimated capacity includes the typical number of floor seats (1,088) for this configuration. Capacities based on your needs may vary.

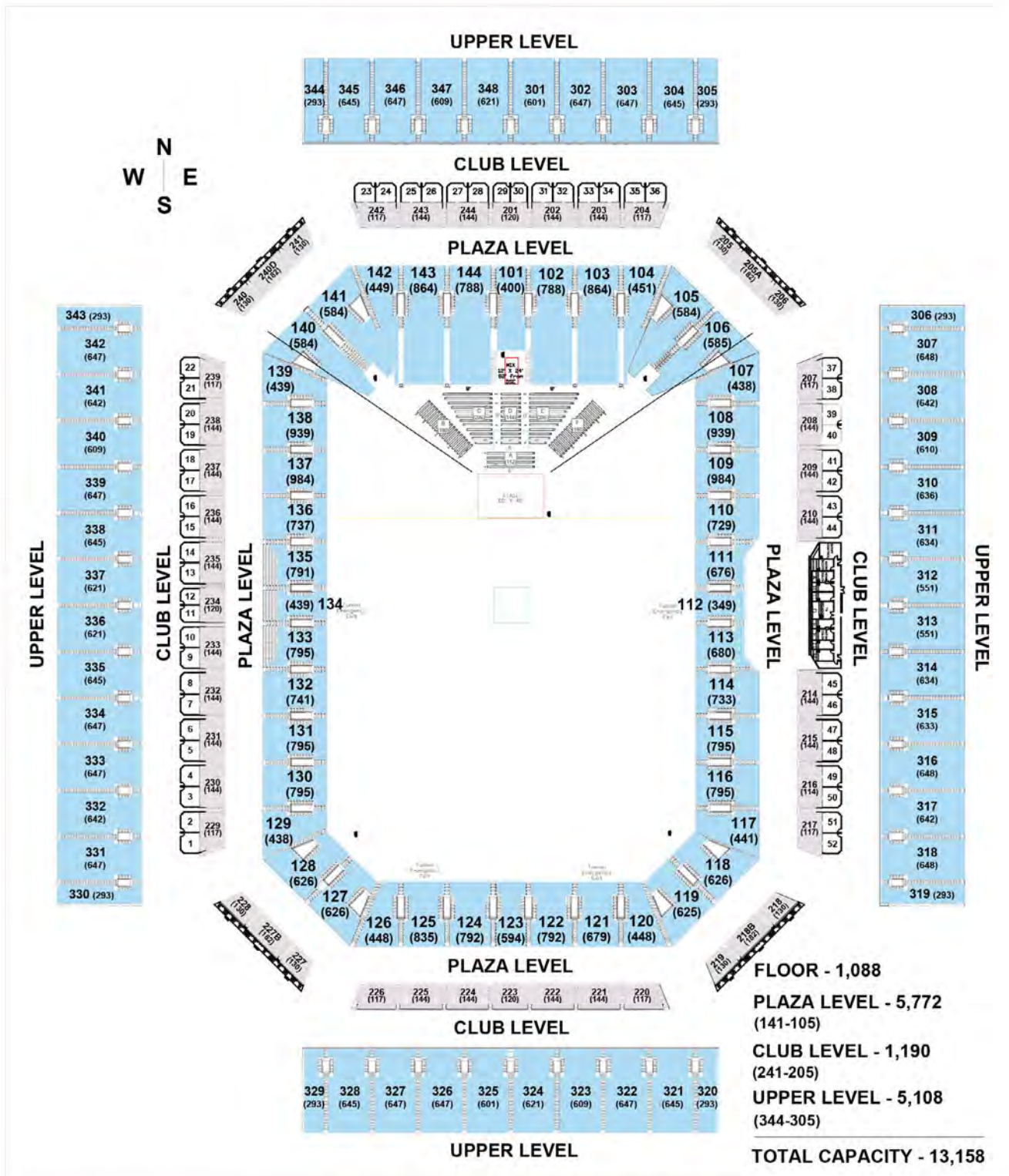

laskercadservices.com

Theatre  
(13,158)



06/27/22



# Arena - Boxing

\*The estimated capacity includes the typical number of floor seats (2,004) for this configuration. Capacities based on your needs may vary.

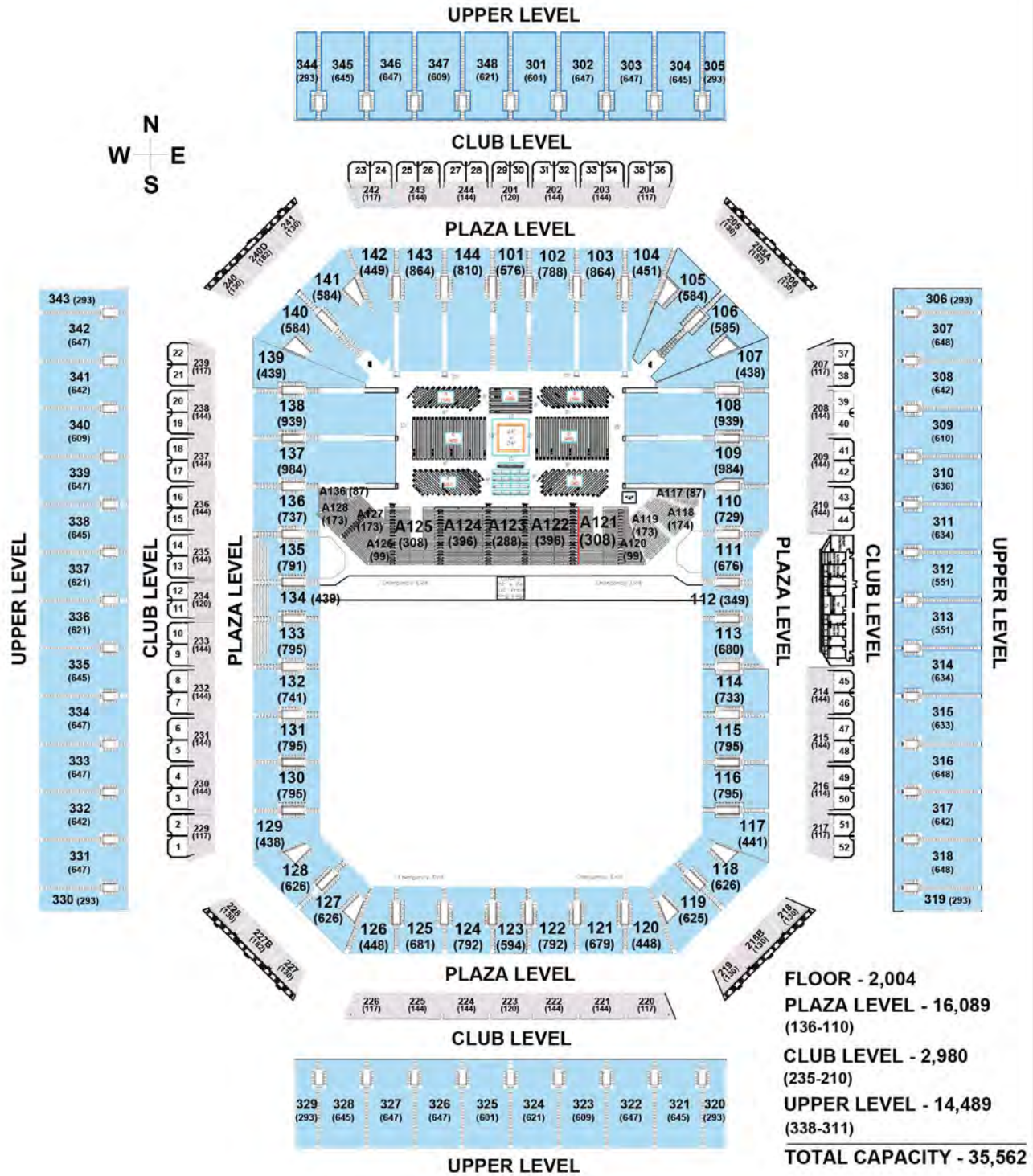

laskercadservices.com

Arena  
Boxing  
(35,562)



02/23/22

# Arena - Graduation

\*The estimated capacity includes the typical number of floor seats (1,440) for this configuration. Capacities based on your needs may vary.

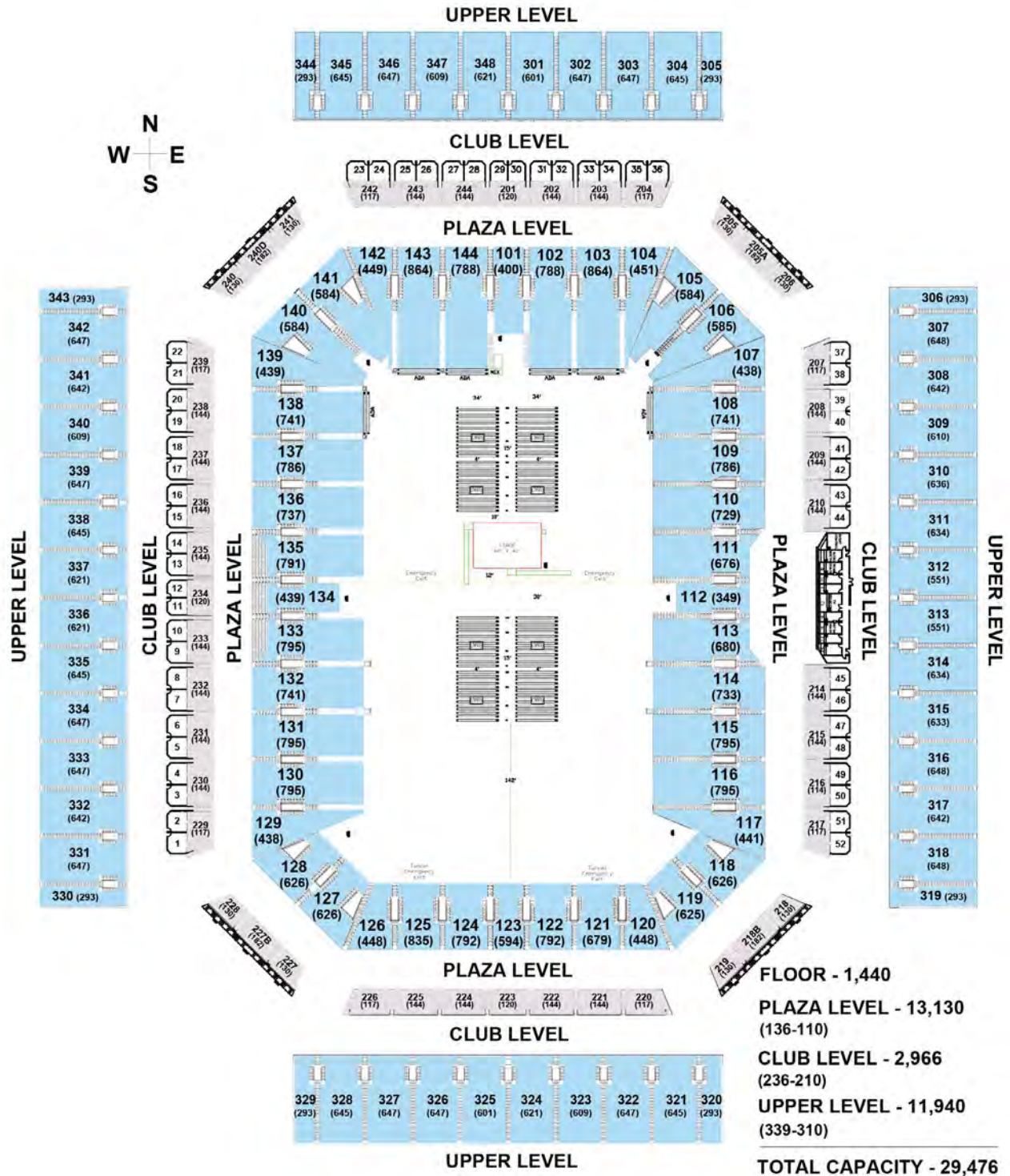

laskercadservices.com

Arena  
Graduation  
(29,476)



04/28/22



# Modified Arena - South Stage

\*The estimated capacity includes the typical number of floor seats (2,612) for this configuration. Capacities based on your needs may vary.

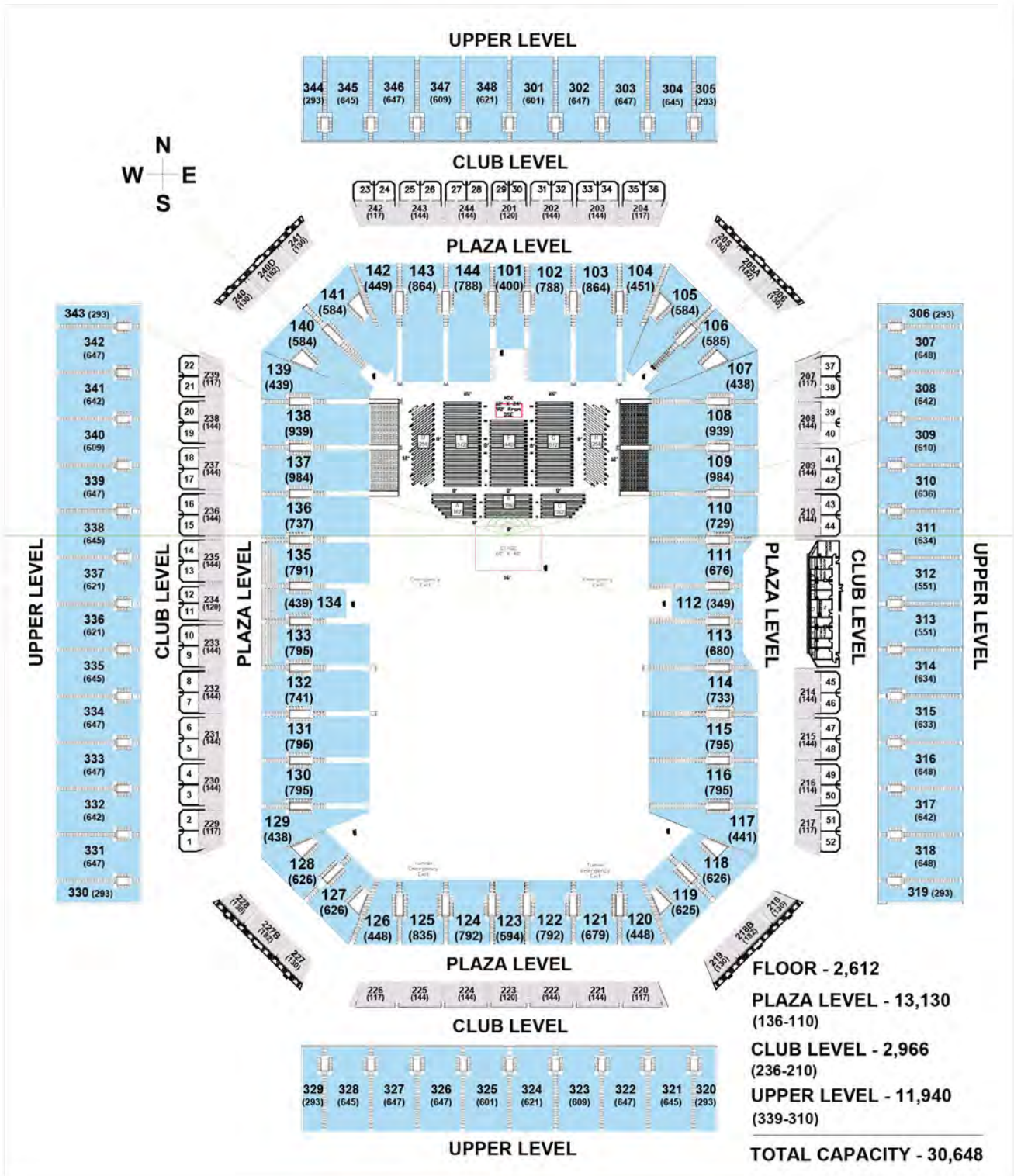

# Arena - East Stage

\*The estimated capacity includes the typical number of floor seats (2,574) for this configuration. Capacities based on your needs may vary.

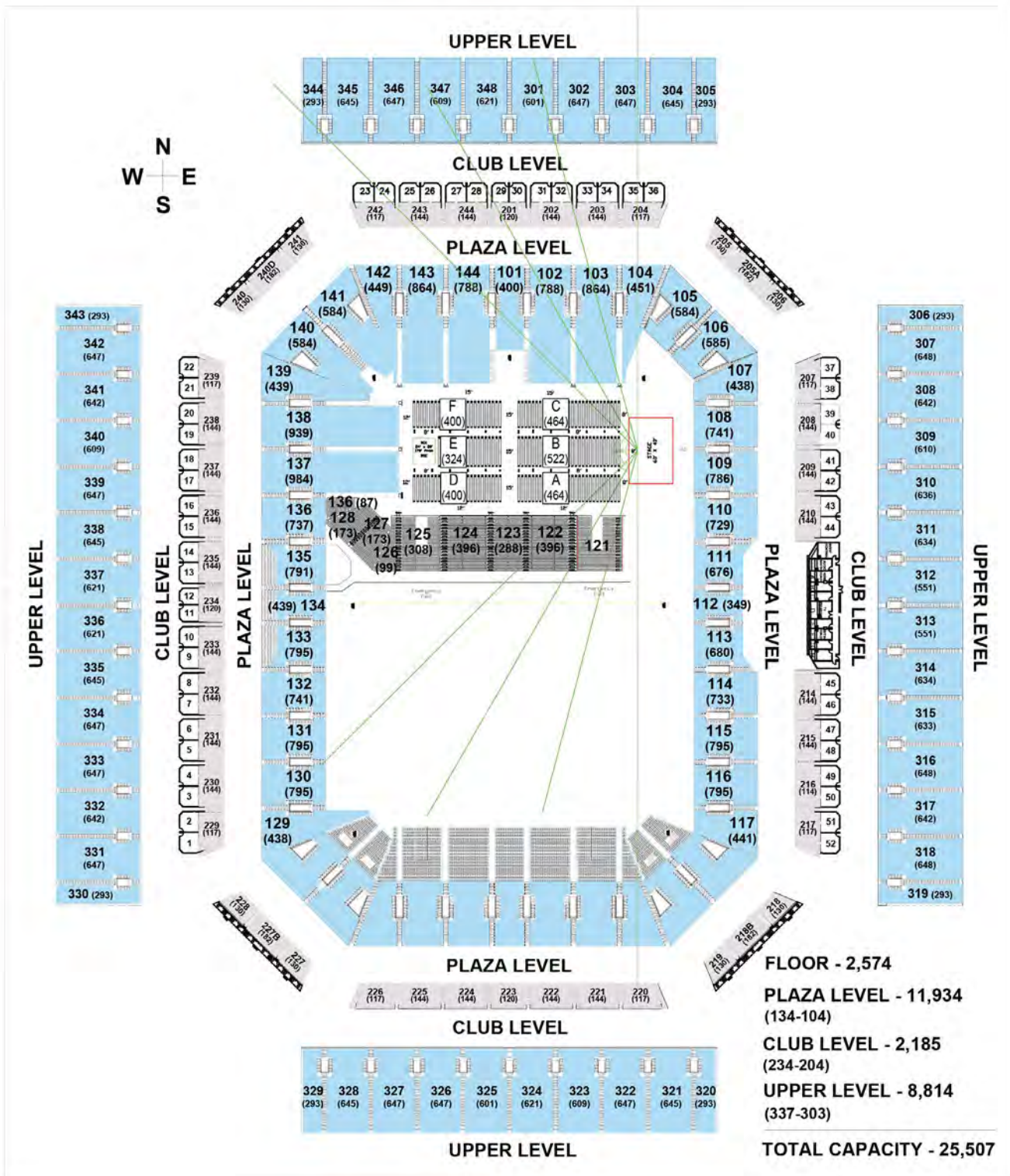

laskercadservices.com

Arena  
East Stage  
(25,507)



04/28/22

# Tradeshow

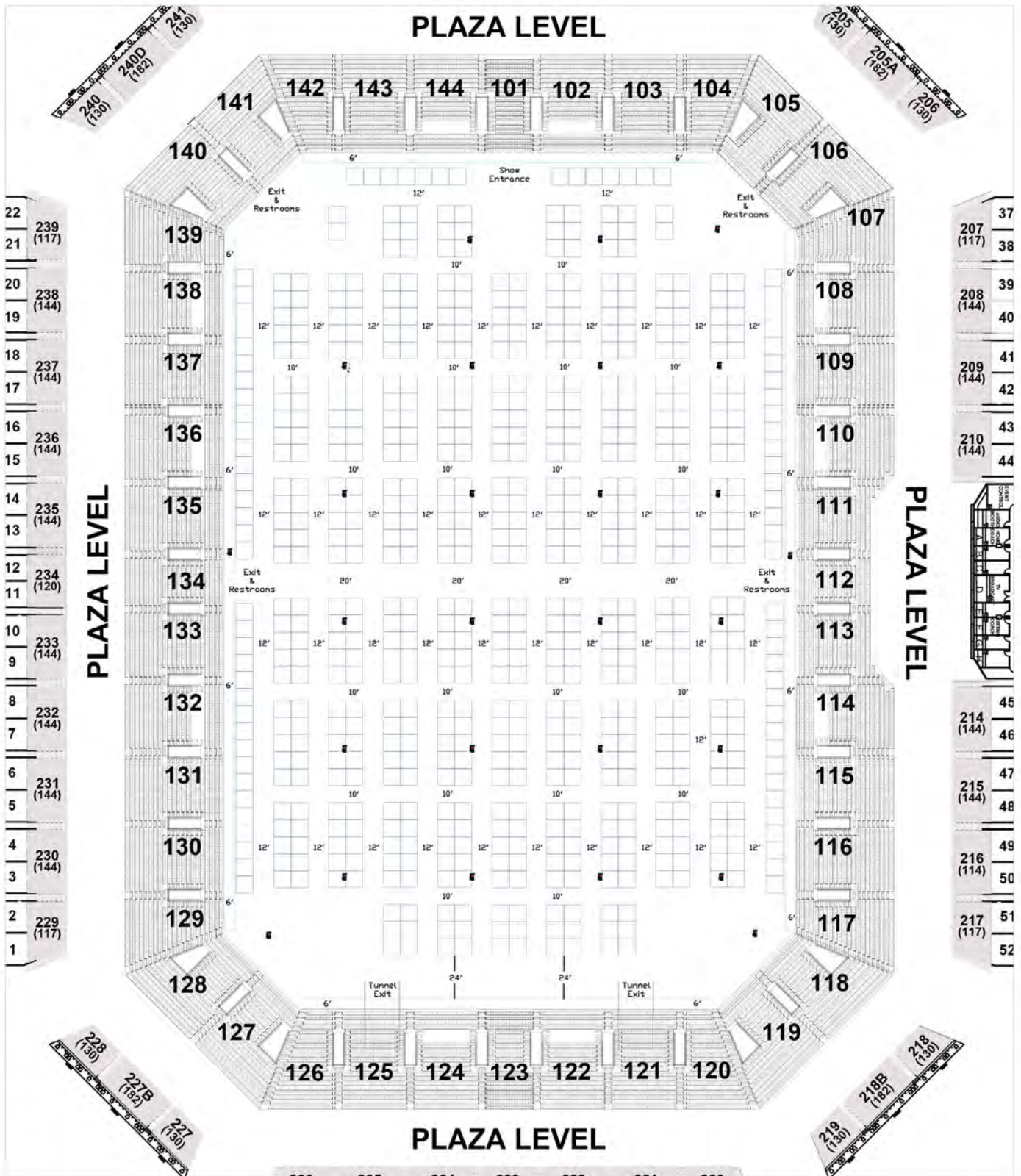

**LASKER**  
 CAD SERVICES  
[laskercadservices.com](http://laskercadservices.com)

Stadium  
 Trade Show  
 (680 10' x 10' Booths)

03/03/22

# Room Configurations

## Locker Rooms - Backstage Rooms

Room Name*	Square Feet	Restrooms	Showers	Lockers	Additional Features
Locker Room A	1,071	X	X	32	Head Coach Locker Room w/shower
Locker Room B	897	X	X	39	Head Coach Locker Room w/shower
Locker Room C	897	X	X	40	Head Coach Locker Room w/shower
Locker Room D	1,174	X	X	33	Head Coach Locker Room w/shower
NE Locker Room	5,300	X	X		Head Coach Locker Room w/shower
Home Team Locker Room	7,500	X	X	132	Equipment Room, Training Room, Coaches Lounge,
W. Officials Locker Room	500	X	X	13	
E. Officials Locker Room	500	X	X	13	
X-Ray Room	391				
Visitors Interview Booth	180				Broadcast Connections
Home Interview Booth	180				
Production Office	1,700				Air wall divider equipped
North Dressing Room	166	X	X		Part of Production Office Compound
South Dressing Room	166	X	X		Part of Production Office Compound
Green Room	977	X			

\* Please note that Locker Rooms A/B and C/D are air wall equipped and may be combined. Production Office and NE Locker Room are wall equipped and may be split in half.

# Room Configurations

## Meeting Rooms

Meeting Rooms	Gross Sq. Ft.	Approx Room Size	Theater	Classroom	Banquet	Ceiling Height
A	1,506	37'x42'	104	52	63	12' 6"
B	2,338	37'x63'	156	78	94	12' 6"
A&B	3,844	37'x105'	260	130	157	12' 6"
C	1,830	41'x45'	123	62	74	12' 6"
D	1,830	41'x45'	123	62	74	12' 6"
C&D	3,660	41'x90'	246	124	148	12' 6"
F	2,338	37'x63'	156	78	94	12' 6"
G	1,506	37'x42'	104	52	63	12' 6"
F&G	3,844	37'x105'	260	130	157	12' 6"
I	1,830	41'x45'	123	62	74	12' 6"
J	1,830	41'x45'	123	62	74	12' 6"
I&J	3,660	41'x90'	246	124	148	12' 6"
K	3,059	37'x83'	205	103	123	12' 6"
L	3,059	37'x83'	205	103	123	12' 6"
K&L	6,118	37'x166'	410	206	246	12' 6"
M	1,149	37'x32'	79	40	48	12' 6"
N	2,159	41'x54'	148	74	89	12' 6"
O	1,826	41'x54'	123	62	74	12' 6"
P	1,826	41'x54'	123	62	74	12' 6"
N/O/P	5,811	41'x144'	394	198	237	12' 6"

## Press Box

### Details

- Seating for 150 persons
- Located on the East 50-yard line Mezzanine level
- An additional room measuring 16'x41' is also available
- Four (4) Auxiliary Press areas can be created throughout the Mezzanine level, each seating approximately 30 persons.

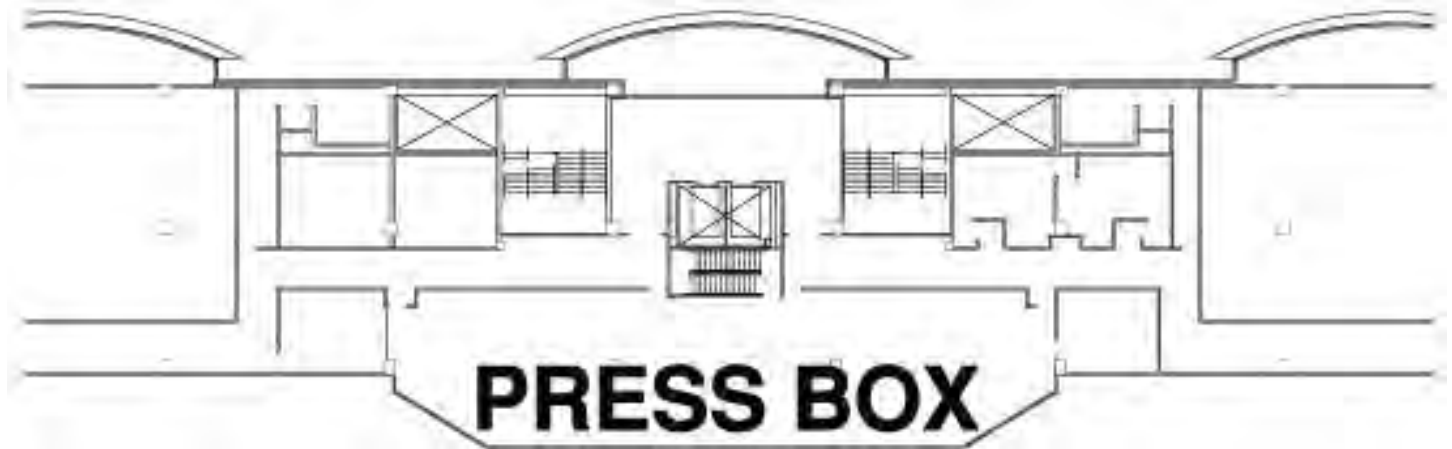

## Coaches/Broadcast Booths

### Details

- 9 total booths available (A-I)
- Located directly above the Press Box on the East 50-yard line Club level
- Inner stairwell to Press Box for easy access

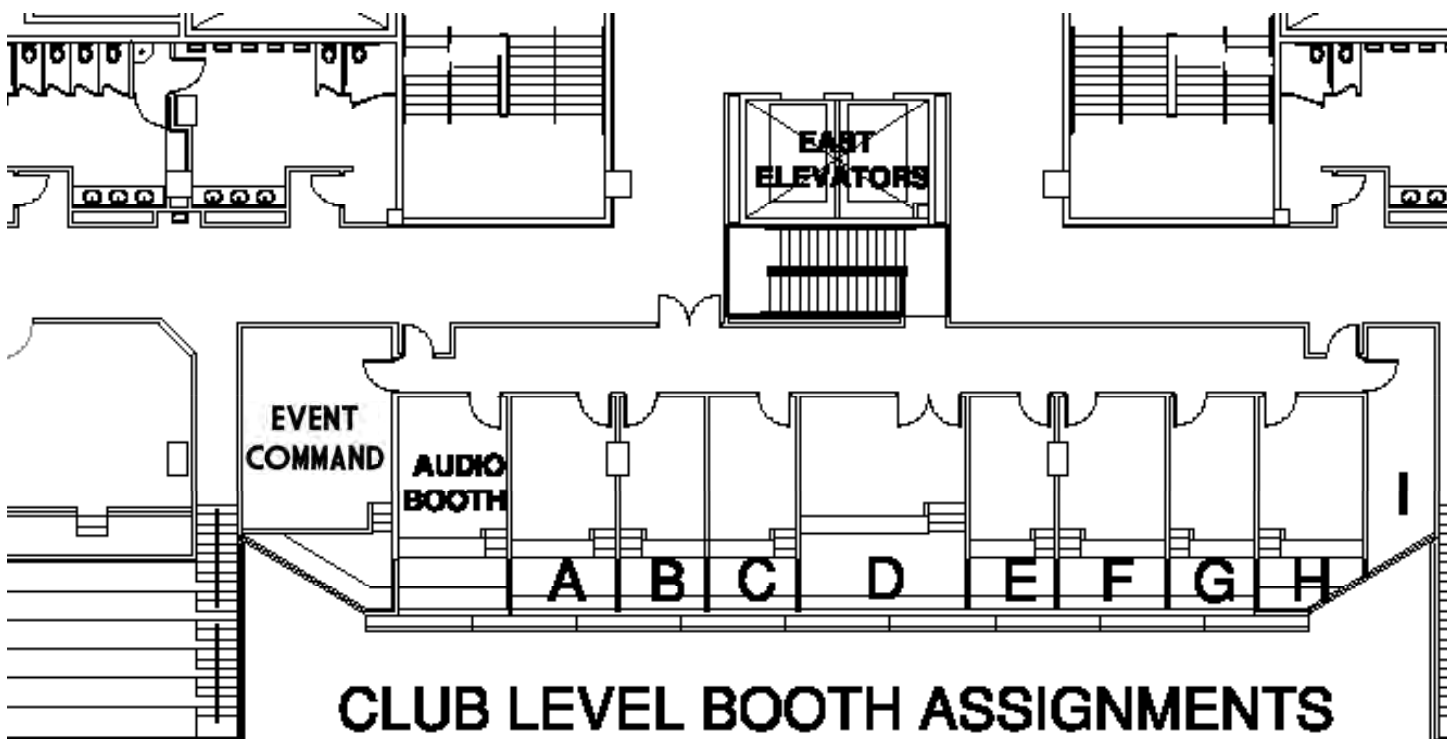

# Suites

Our Club Level includes 52 private rooms, with seating for up to 12, 14, 15, or 16. Suites have been renovated to enhance the elegant design and provide the most up to date technology.

Suite Packages Include

- Parking
- Customized Menus
- Exclusive Catering Prices

Delicious food, refreshing beverages and outstanding service are only a few of the amenities that make your experience unforgettable. In a luxury suite at the Alamodome you will have the best seats for concerts and sporting events while leaving a lasting impression on your valued clients, employees, family and friends.

In addition to the private spaces, be sure to ask about our open air terrace suite space. Terrace suites overlook the Dome floor or field and can be personalized to accommodate 20-100 guests for an event or gathering.

For information on leasing an Alamodome suite, please email [suitesales@alamodome.com](mailto:suitesales@alamodome.com).

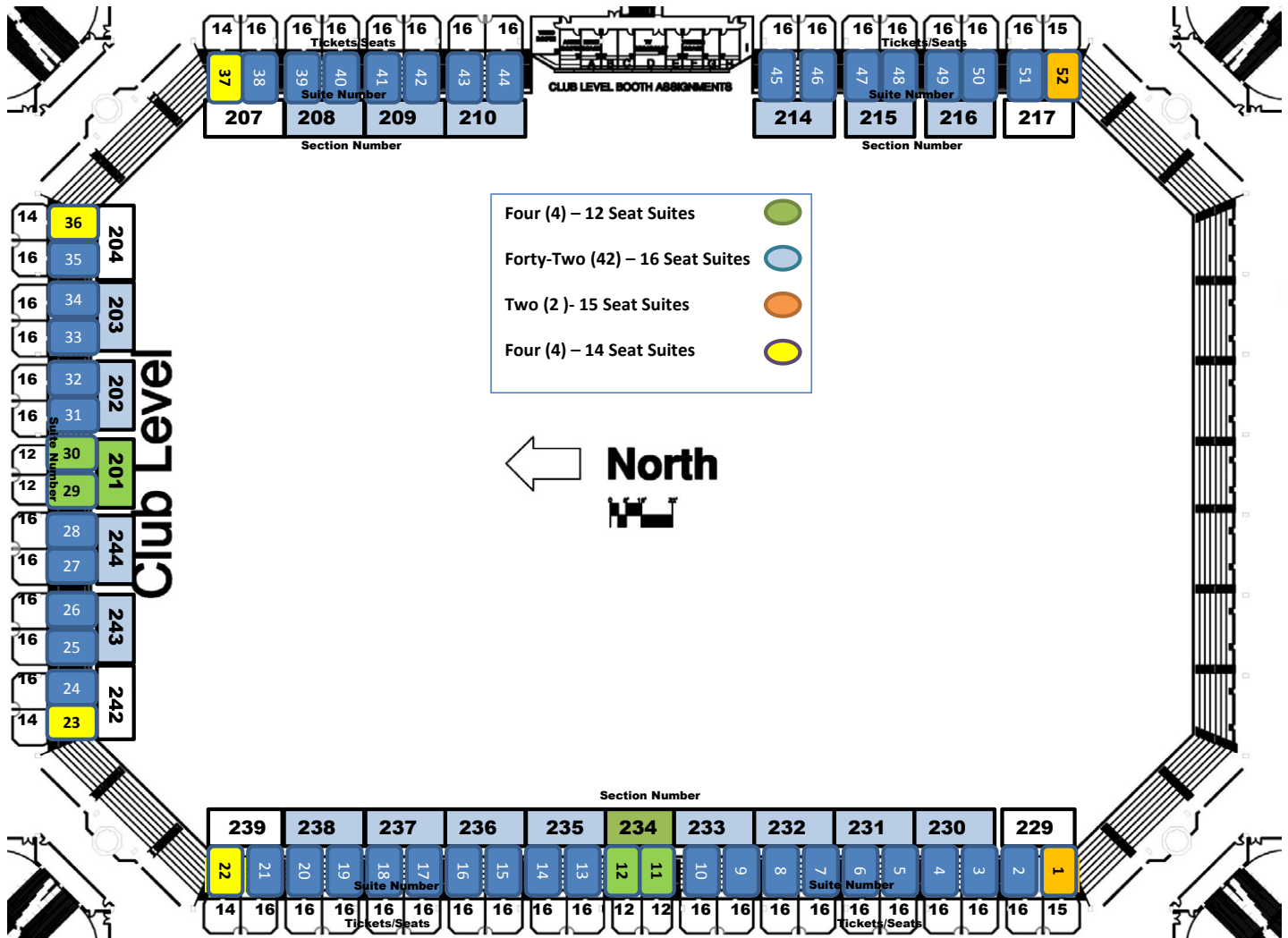

# Hospitality Spaces

## Hall of Fame Club

Located on the North end of the Club Level, the Hall of Fame Club offers over 4,000 square feet with spectacular views of the HEB Plaza and downtown San Antonio, two built in bars, and large flat screen TV's to enjoy the event from a private location.

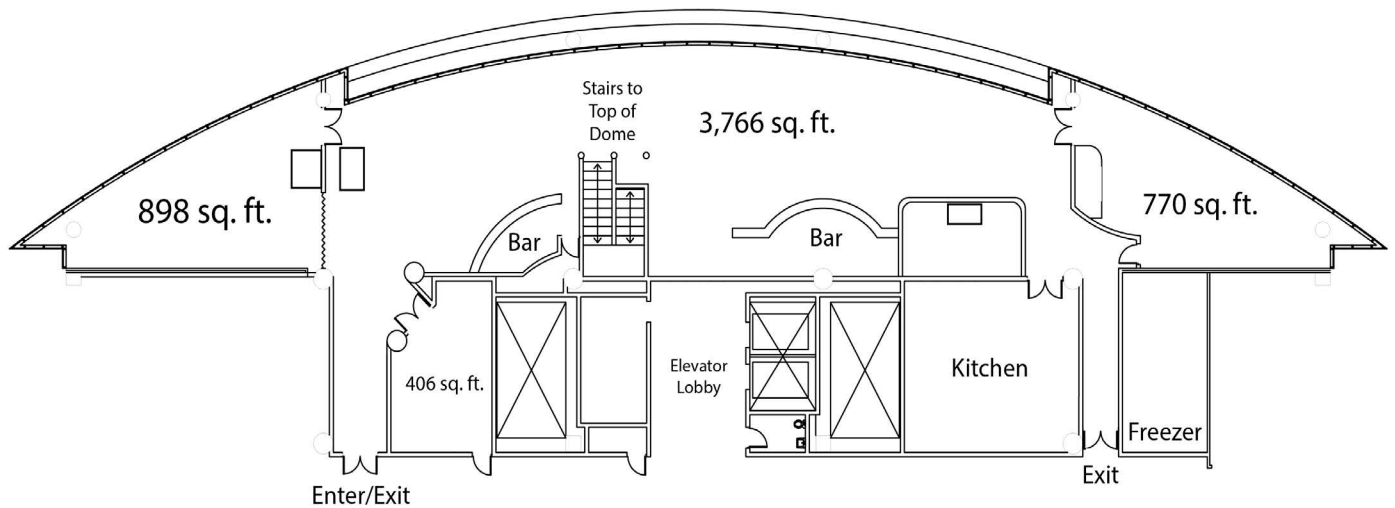

## Top of the Dome Club

Located on the North end of the Upper Level, the Top of the Dome Club can function as its own private 3,500+ square foot space, or use the connecting staircase to the Hall of Fame Club to double the size of your party.

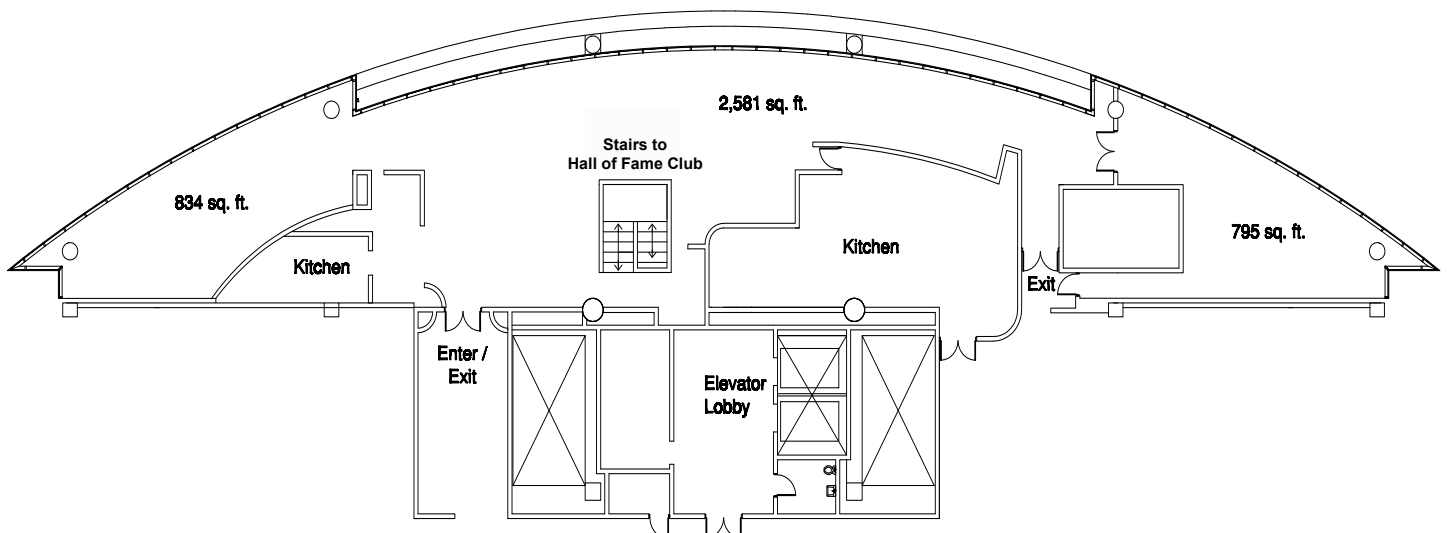



## South Club Eyebrow

Located on the South end of the Club Level, over 6,000 square feet of flexible and completely customizable space without any built in fixtures is the perfect place to make the Alamodome your own.

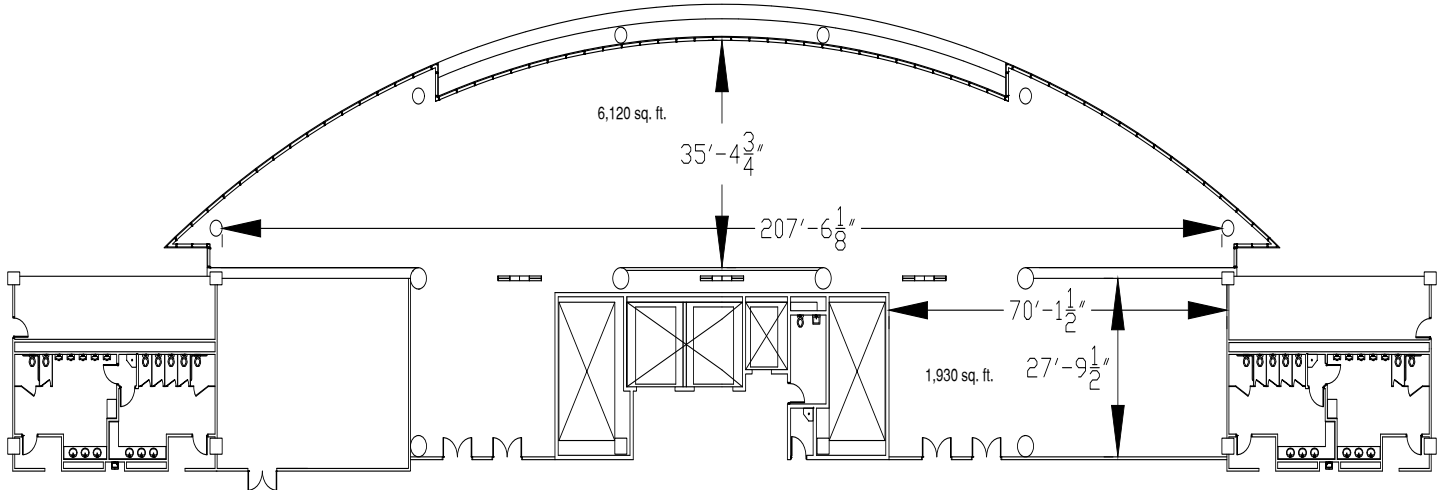

## Multi-purpose Room

This 23,000 square foot multi-purpose space is located on the North end of the field level. This brand new area features a separate loading dock, offering convenient access to Montana St.



# Parking

At the Alamodome we understand that parking is an important concern for our event organizers and attendees, especially in a downtown setting. Our dedicated parking team has developed guidelines and procedures and will work with your Event Coordinator to plan and meet your transportation needs.



LOT	TOTAL SPACES	LOT SIZE SQ. FT.	ADA	BUS	LOCATION	RELATION TO BUILDING
A	748	334,683	127	12	Corner of East Cesar E. Chavez Blvd. and I-37 (U.S. Hwy. 281) Frontage Road	South
B	968	343,976	0	15	South Cherry Street	East
C	1,142	360,552	0	0	South Cherry Street	East
<b>TOTAL</b>	<b>2,858</b>		<b>127</b>	<b>27</b>		

## **Accessible Parking and Drop-Off**

Accessible parking is located in Lot A, off of the Northbound IH-37 access road, between César E. Chávez Blvd. and Montana St. The Alamodome provides 127 accessible spaces that are available on a first come, first served basis for vehicles with a valid State issued placard (blue or red) or license plate. Accessible parking is subject to the event parking rates. Complimentary drop-off and pick-up for patrons with disabilities is available in Lot A, as well as an accessible ramp leading to the Plaza level.

## **Patron and Ride Share Drop-Off/Pick-Up Area**

The drop-off and pick-up zone is available for quick access in Lot D located at Tower of the Americas Way (southbound I-37 access road) between Montana and César E. Chávez Blvd. Drop-off and pick-up at this location is the safest and quickest area for ride share, taxis, and limo access. There is a pedestrian walkway that leads directly from this location to the security checkpoint on the North Plaza of the Alamodome, Access Control Point (ACP A).

### **Ride Share Zone Address:**

**500 Tower of Americas Way**

**San Antonio, TX 78205**

## **Bus Parking**

Bus entry and parking is available in the North section of Lot B, on Cherry Street, and is most easily accessed by entering the parking lot from the North.

## **Overnight Parking**

Overnight guest parking is not permitted in any of the Alamodome parking lots. Arrangements for production vehicles to stay overnight can be made through your Event Coordinator.

## **Traffic**

The San Antonio Police Department's Traffic Division assists the Alamodome with traffic direction during many events. The amount of police coverage depends on the Alamodome event size and scope.

## **Loading Dock**

### **Loading Dock Specifications**

- The loading dock is located at the south end of the Alamodome, in Parking Lot A, and is accessible via the Northbound I-37/U.S. Route 281 Frontage Road.

- The loading dock features 4,200 square feet of space including eight truck bays with two direct access tunnels to the stadium.
- Loading Dock bays measure 17' 9" wide and 10' high. Bays are 82' deep.

## **Loading Dock Access**

- Loading Dock access is restricted to Loading Dock permit holders. Loading Dock parking permits may be obtained through your Event Coordinator.
- Persons requesting Loading Dock access to load and/or drop off equipment must be approved by the client and communicated to the Event Coordinator. Approved guests will be permitted to park in the designated 15-Minute Loading Zone parking spaces or in loading dock bays, as applicable, based on availability.
- Alamodome tenants may park in the 15-Minute Loading Zone parking spaces at any time, provided space is available and timing does not impact event operations.
- Commercial carriers will also be granted access to the appropriate loading dock bays, as designated by Security, upon availability.

## **Event Day Load In/Load Out**

- Licensee staff needing to load and/or unload in the Loading Dock area before the event is permitted to do so up to 2 hours prior to the start of the event. Licensee staff needing to load and/or unload after the end of the event may begin to do so 1 hour after the end of the event. There is no parking permitted in the loading dock area for these vehicles.

## **HEB North Plaza Vehicle Access**

- Vehicle access to the HEB Plaza on the North side of the Alamodome can be obtained with prior approval from your Event Coordinator. Access to the HEB Plaza will be limited to vehicles being used in the setup, display, or break down of events taking place on the Plaza. All vehicles entering through the North Plaza must maintain a maximum weight of 250 lbs. per sq. ft. or less.
- Access to the HEB Plaza via Sunset Station is blocked by bollards owned by VIA Metropolitan Transit. Clients must obtain approval from VIA Metropolitan Transit for the entry of vehicles with a gross weight of 40k lbs. or more.
- If you must enter through Sunset Station, please provide your Event Coordinator with a schedule of the times you will require the bollards to be staffed, at least a week in advance of your event.



# PRODUCTION

**In this section, you will find information regarding AV specifications for the video walls and ribbon boards, equipment, personnel, event power locations, rigging, roof grid and catwalks, fire safety requirements, permitting and our labor rate card.**

# A/V Specs for Video Walls and Ribbons

**\*All graphics and videos must be submitted one week prior to event**

## Corner Video Walls and White Box Center Hung boards

HD Video Commercials & Moving Graphics:

- 1080i or 1080p / 29.97fps
- .mov or mpg4
- NO 24 FPS COMMERCIALS
- NO FLASH FILES/ FLASH ANIMATION

Stills:

- .png (if alpha needed) / .jpeg (If alpha not needed)
- Width: 1920 / Height: 1080
- Resolution: 72 Pixels/Inch
- Color Mode: RGB Color / 8 bit
- Color Profile: Don't Color Manage
- Pixel Aspect Ratio: Square Pixels
- Use these settings in Photoshop

## 360 Ribbon Boards

Motion Graphics:

\*The ribbon boards are divided into 4 separate sections. Please keep this in mind when creating a continuous 360 ring.

- Width: 9088px / Height: 64px
- Pixel aspect ratio: Square Pixels
- Frame Rate: 59.94 fps
- .mov or mpg4
- NO FLASH FILES/ FLASH ANIMATION

Stills:

\*The ribbon boards are divided into 4 separate sections. Please keep this in mind when creating a continuous 360 ring.

- .jpeg / .targa / .png
- Width: 9088px / Height: 64px
- Resolution: 72 Pixels/Inch
- Color Mode: RGB Color / 8 bit
- Color Profile: Don't Color Manage
- Use these settings in Photoshop

# ALAMODOME RIBBON BOARD LAYOUT

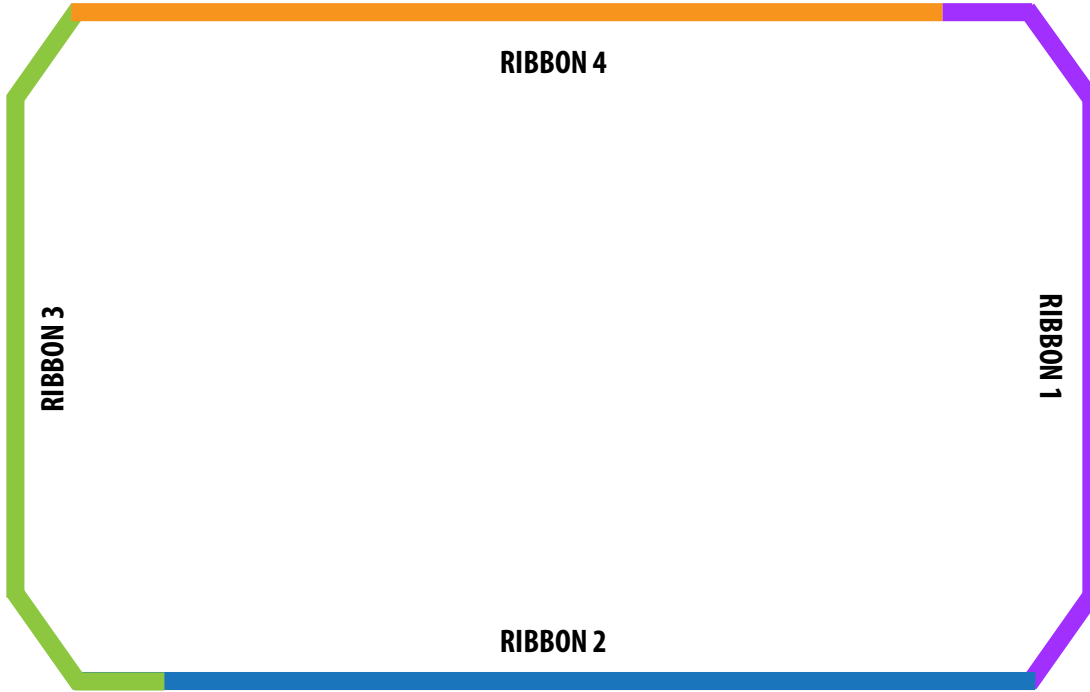

← NORTH

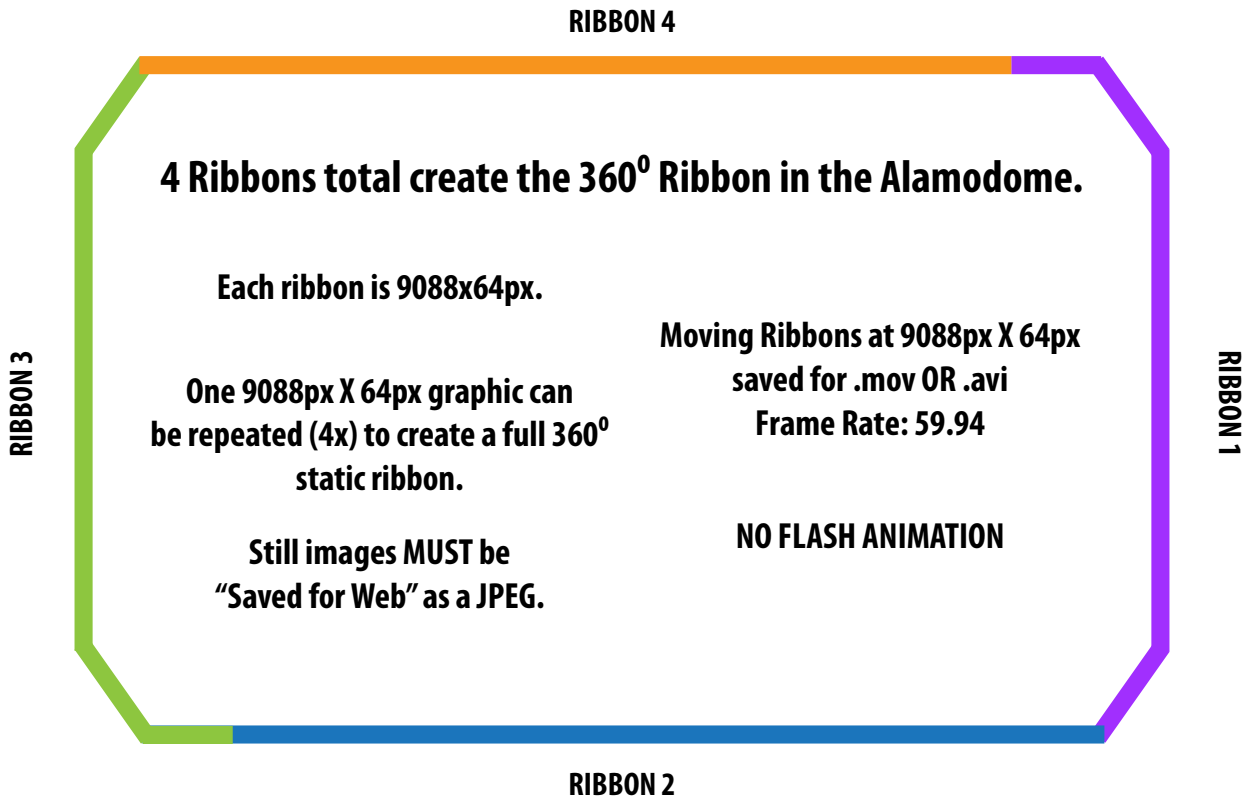

← NORTH



# ALAMODOME STATIC RIBBONS WITH SCOREBOARD MUST BE DESIGNED AS FOLLOWS

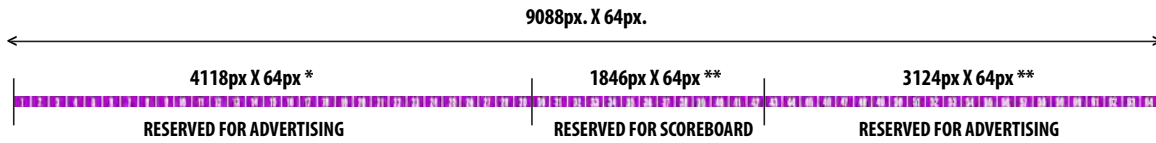

\* BLOCKS 1 - 29 RESERVED FOR ADVERTISEMENT • 4118px X 64px



\*\* BLOCKS 30 - 42 RESERVED FOR SCOREBOARD • 1846px X 64px



\*\*\* BLOCKS 43 - 64 RESERVED FOR ADVERTISEMENT • 3124px X 64px

ALL ribbons are numbered 1- 64  
Each number block is 142px.  
142px. X 64(blocks) = 9088px.



## ALAMODOME STATIC RIBBONS WITH SCOREBOARD EXAMPLES



**DESIGNERS NOTE:** FILE IMAGE MUST FILL ENTIRE RIBBON (9088X64) DO NOT CUT OFF DESIGN AT BLOCKS 30-42.  
JPEG SHOULD BE EXPORTED IN RGB COLOR MODE, 9088px X 64px AT 100% FILE SIZE AT 72 dpi. BEST IF "SAVED FOR WEB".  
DO NOT ARRANGE ANY LOGO WITHIN RESERVED SCOREBOARD AREA.

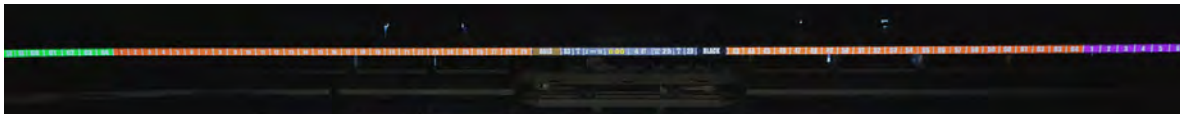

RIBBON 4 EXAMPLE ■





# Equipment & Personnel

The Alamodome has Video Production Equipment and Personnel that can be provided at an additional cost per event. All Equipment and Personnel must be requested at least two weeks prior to the scheduled event.

## Cameras:

- 3 -- Ikegami HDK-65C/BDT Cameras with XJ80X8.8B/P01-DSS with full camera support and CCU's 1080i
- 3 -- Ikegami HDK-65C/BDT Cameras with HJ24EX7.5B with full camera support and CCU's 1080i
- 1 -- Ikegami HDK-65C/BDT wireless Camera with HJ14eX4.3B with full camera support and CCU's 1080i

## Instant Replay:

- 1 -- Evertz DreamCatcher Replay System 8 channels, pan and zoom, High frame rate camera support

## Ribbons & Graphics:

- 2 -- Ross Dual Channel Xpression Studio CG

## Switcher

- 1 -- Ross Acuity 4ME, 32 input switcher

## Digital Recorder:

- 4 -- AJA 4K/Ultra HD and 2K/HD Recorder/Player



# Event Power Availability

## 6,770 Total Amps, 600A Total Amps 480V

### Cables & Ramps In-House

- (81) Yellow Jackets/Cable Ramp
- (8) 3ft ADA Cable Ramps
- (24) 1 1/2ft ADA Cable Ramps
- (4 Sets) 150' Show Cable
- (2 Sets) 100' Show Cable
- (1 Set) 75' Show Cable
- (1 Set) 50' Show Cable
- 

### Stadium Lighting

- LED Musco Lighting

### Upper Seating Lighting

- 1500W Metal Halide

### East Loading Dock:

- (3) 200A 3Phase/208V Disconnects w/ Cam-Loks
- (6) 30A 3Phase/208V - (1) 30A 3Phase 208V  
(5 disconnects being used for lift station, charging or other).

### West Loading Dock:

- (3) 200amp 3Phase/208V Disconnects w/ Cam-Loks
- (3) 30A 3Phase 208V & (3) 50A 3Phase 208V

### South East Tunnel:

- (2) 600amp 3phase/208v
- (1) 400 amp 3phase/208v
- (1) 100 amp 3phase/208v

### East 50-Yard Line

- (1) 600 amp 3phase/208v
- (1) 400 amp 3phase/208v

### West 50-Yard Line:

- (1) 600 amp 3phase/208v
- (1) 400 amp 3phase/208v

### Catwalk Disconnect – Center Stadium:

- (1) 800 amp 3phase/208v Disconnects w/ Cam-Loks

### Catwalk Disconnect – North Stadium Area:

- (1) 800 amp 3phase/208v Disconnects w/ Cam-Loks

### Quad C Electrical Room

- (1) 600A 3Phase 208V w/ Cam-Lok Tails

# Power Map

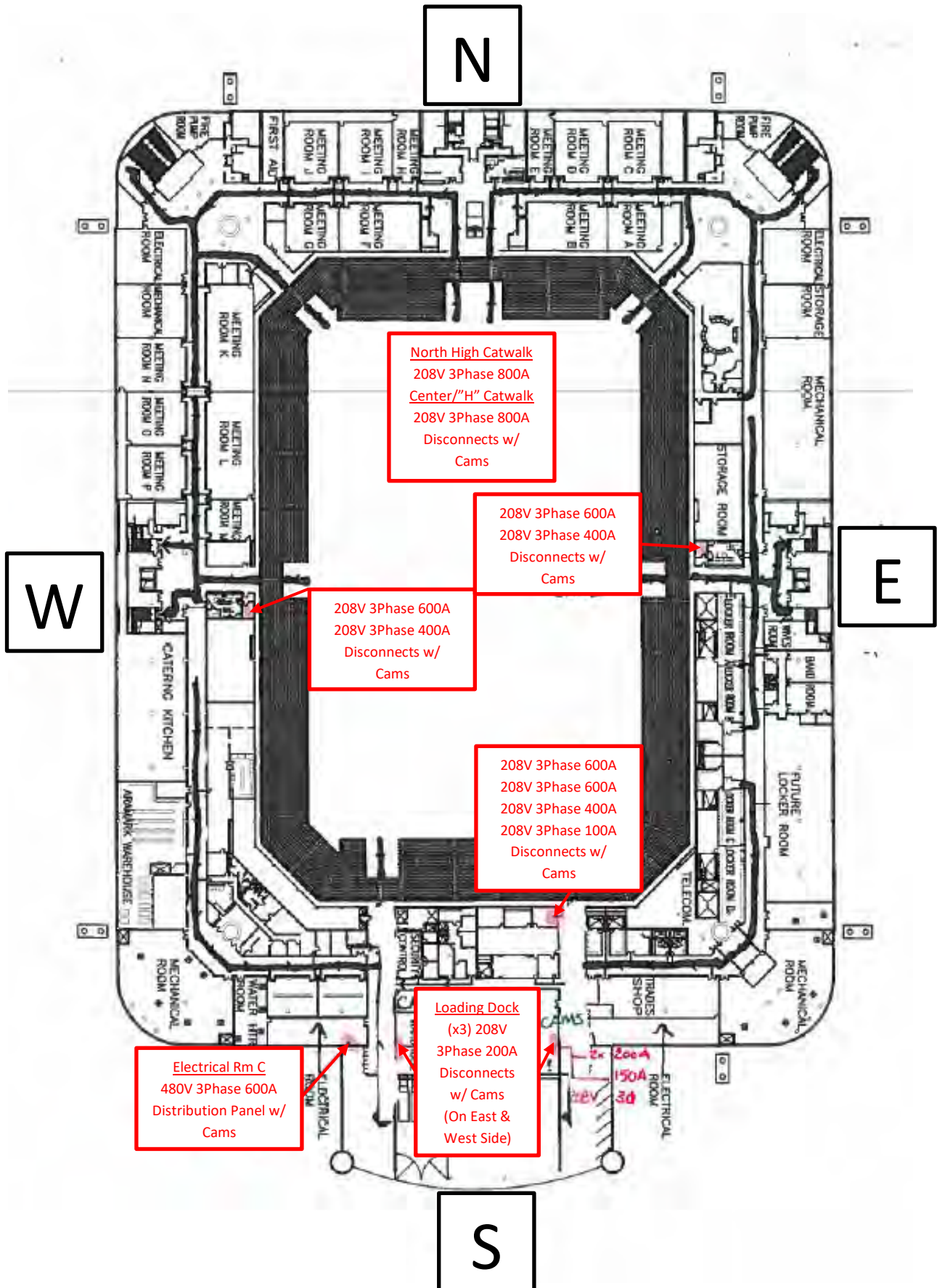

North High Catwalk  
 208V 3Phase 800A  
Center/"H" Catwalk  
 208V 3Phase 800A  
 Disconnects w/  
 Cams

208V 3Phase 600A  
 208V 3Phase 400A  
 Disconnects w/  
 Cams

208V 3Phase 600A  
 208V 3Phase 400A  
 Disconnects w/  
 Cams

208V 3Phase 600A  
 208V 3Phase 600A  
 208V 3Phase 400A  
 208V 3Phase 100A  
 Disconnects w/  
 Cams

Electrical Rm C  
 480V 3Phase 600A  
 Distribution Panel w/  
 Cams

Loading Dock  
 (x3) 208V  
 3Phase 200A  
 Disconnects  
 w/ Cams  
 (On East &  
 West Side)

# Rigging

The rigging of items weighing less than 250 lbs. can be performed by your general services contractor (decorator), or another qualified provider. The rigging of items that weigh over 250 lbs. must be reviewed and approved by a representative of the Alamodome's exclusive rigging company. A certified rigger must hang everything from the chain hoist/motor up to the ceiling.

## Roof, Sound, & Lighting Grid Measurements

- Beams: 10'-6" wide center to center
- Catwalk: 160' from floor
- Bowed Truss Steel (Bottom): 120' from floor
- Bottom of Steel: 164-4" from floor
- Top of Steel: 171' from floor
- Arena North Concert Grid: 60' x 80' 30pt. grid that supports 162k max weight
- Center Floor Concert Grid: 60' x 80' 30pt. grid that supports 162k max weight
- Center Floor Scoreboard Grid: 38' x 57' 18pt. grid that supports 90k max weight
- South Floor Concert Grid: 60' x 80' 35pt. grid that supports 162k max weight

## Seating Unit

Interval Unit Weight:

- 42' unit weighs 26,250 lbs. plus 13,440 lbs. of seating = 39,690 lbs.
- 36' unit weighs 22,500 lbs. plus 10,080 lbs. of seating = 32,580 lbs.

## Stagehands

Licensee is responsible for utilizing a certified stagehand for requirements including rigging, lighting, sound, etc. Stagehand requirements can be coordinated through Upstage Center Inc, the preferred provider of rigging service.

## Floor Weight Capacities

Stadium floor concrete: 3500 PSI and 6000 PSI concrete

Ice Sheets: 1100 PSF

The inside loading dock: 1100 PSF

South plaza over the loading dock: 11000 PSF

# Roof Grid & Catwalk - Full Stadium

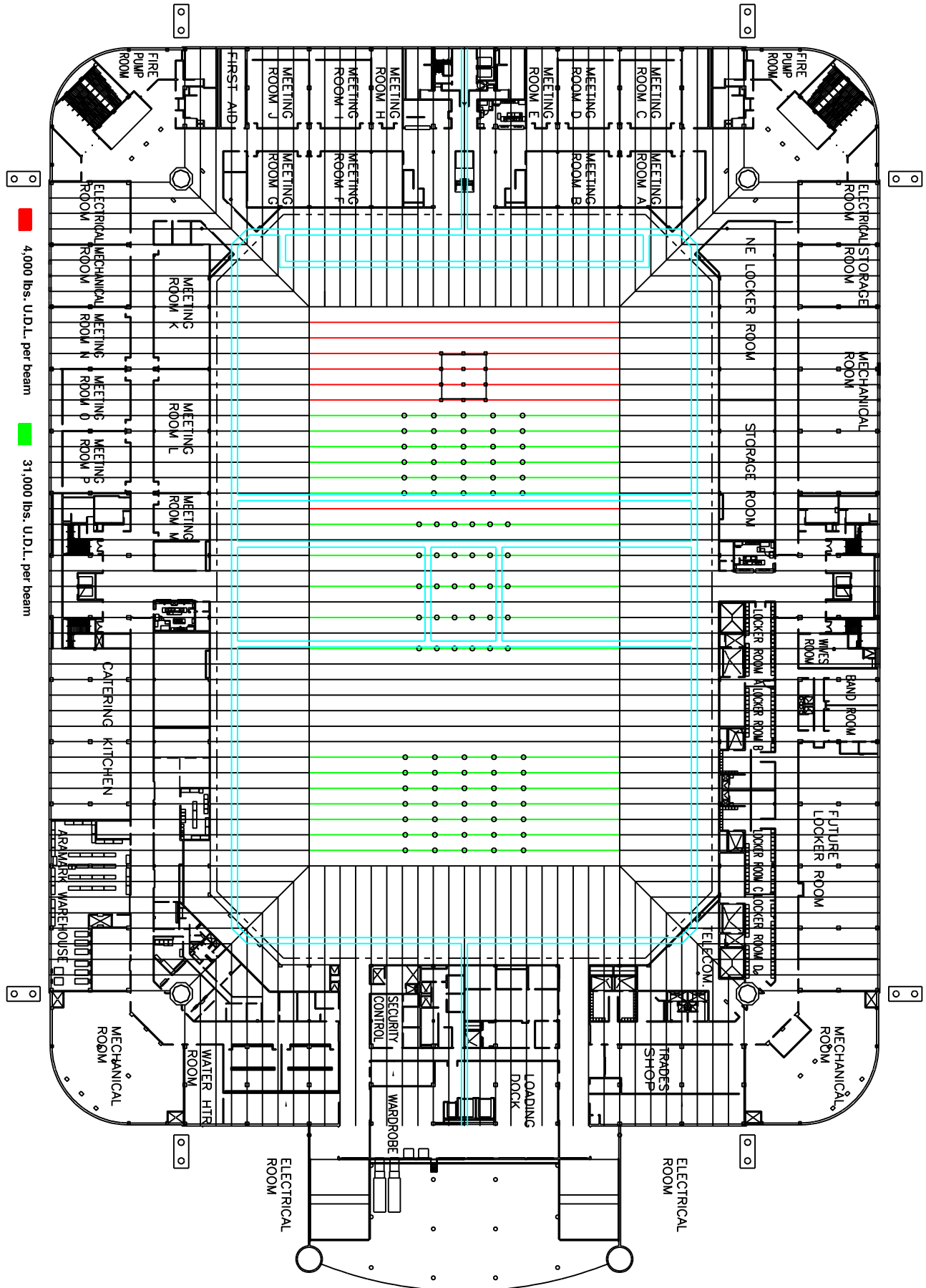

# Roof Grid & Catwalk - Theater

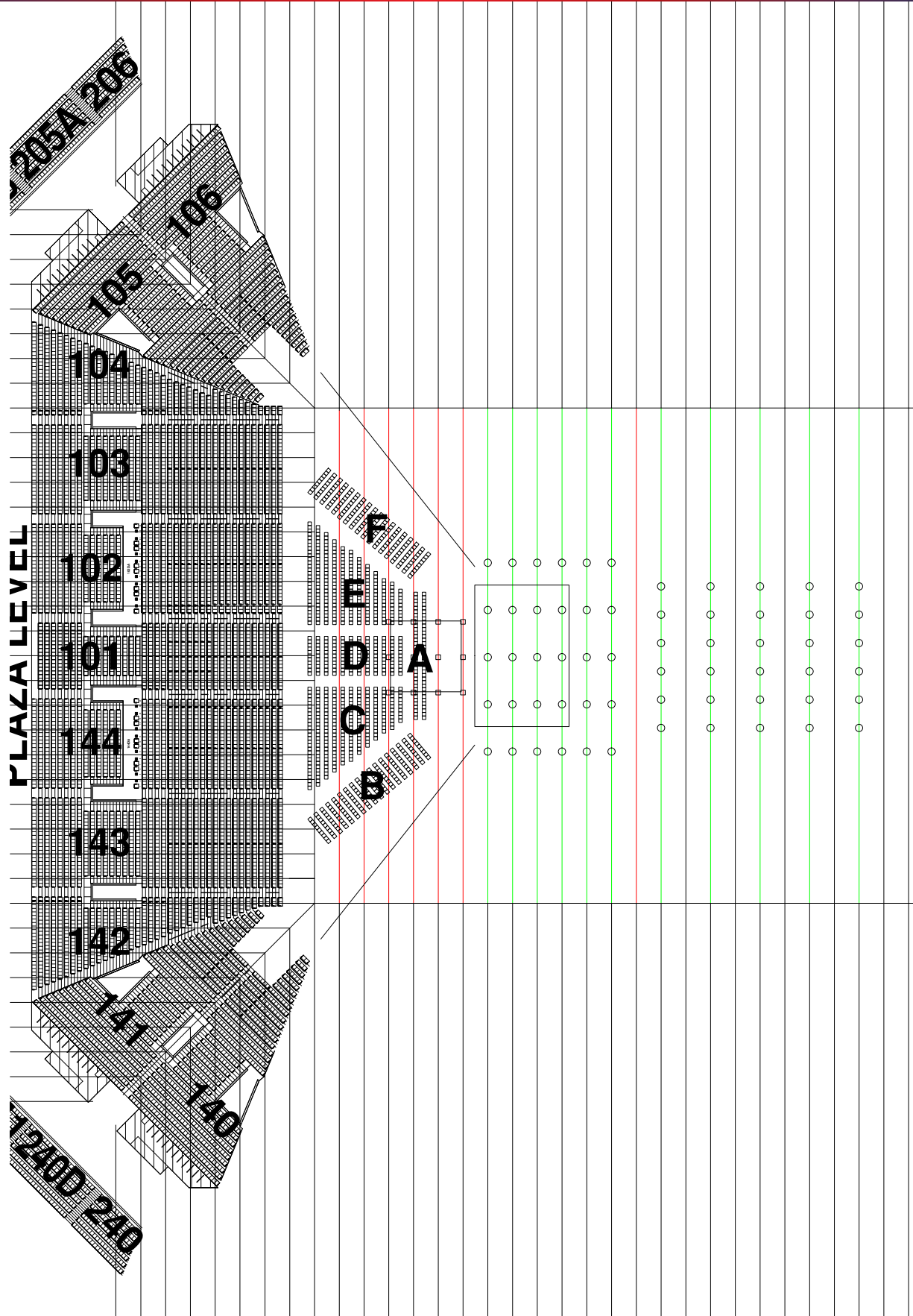

■ 4,000 lbs. U.D.L. per beam    
 ■ 31,000 lbs. U.D.L. per beam



# Plaza Level

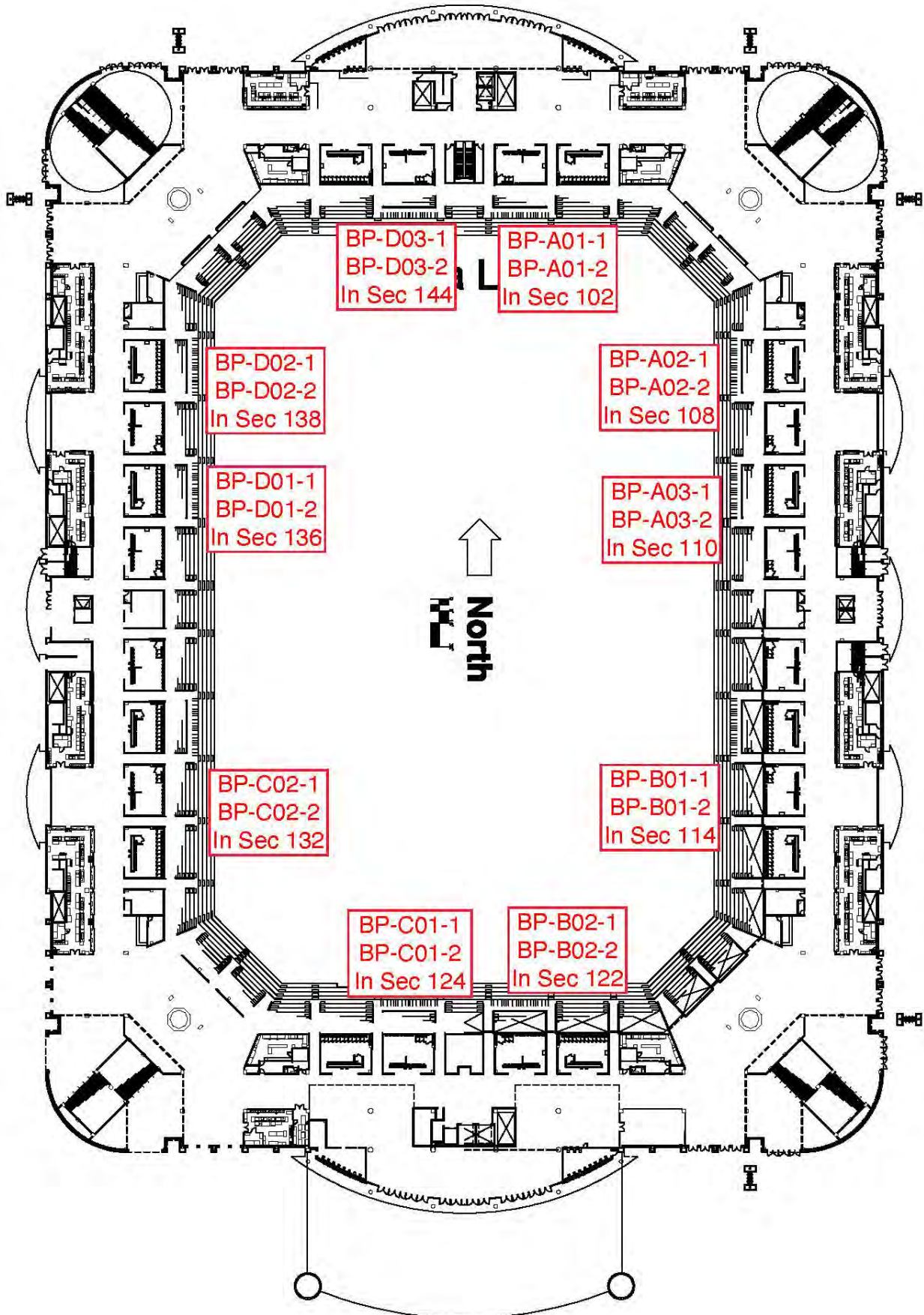



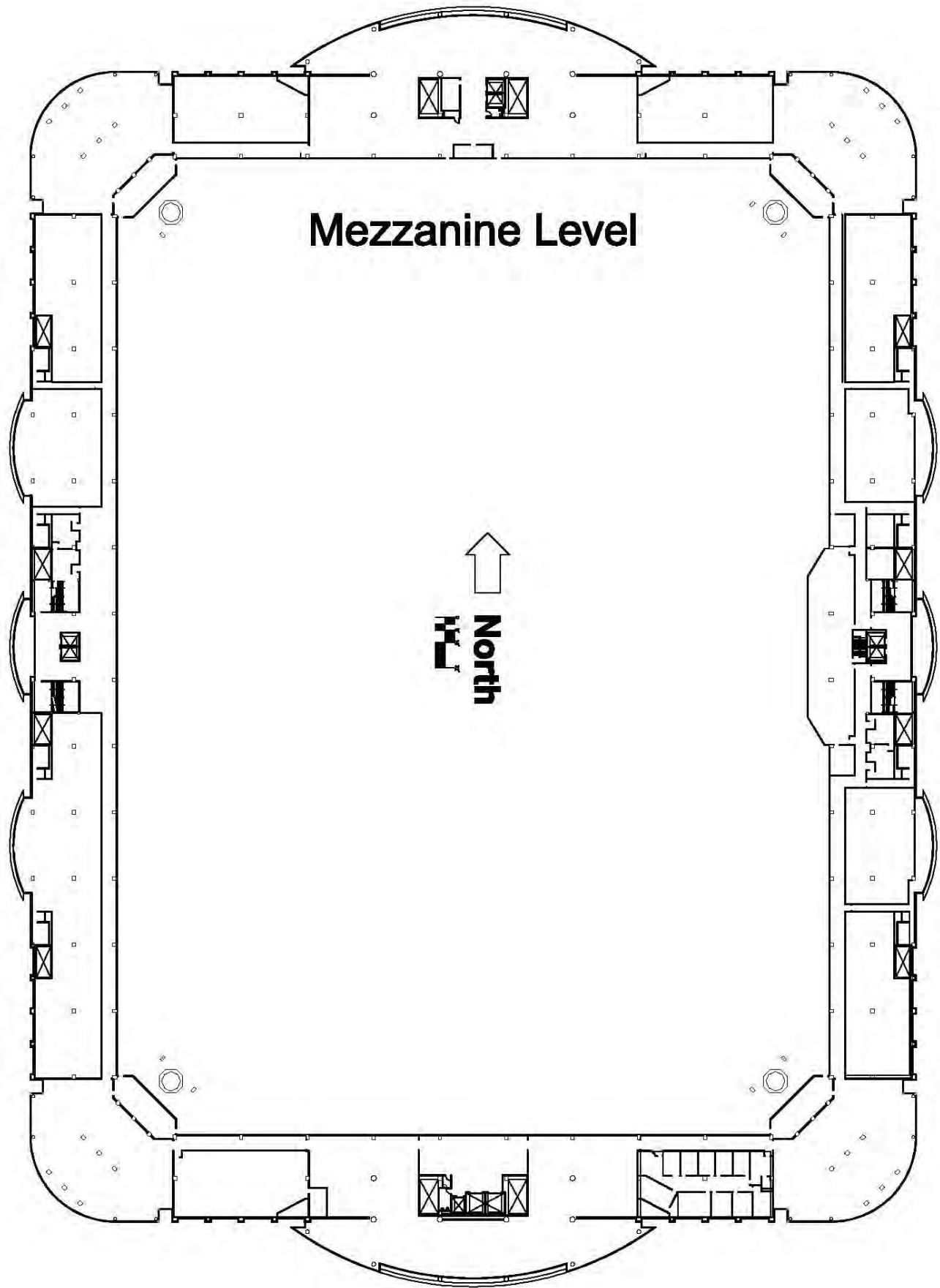

**Mezzanine Level**

↑  
**North**

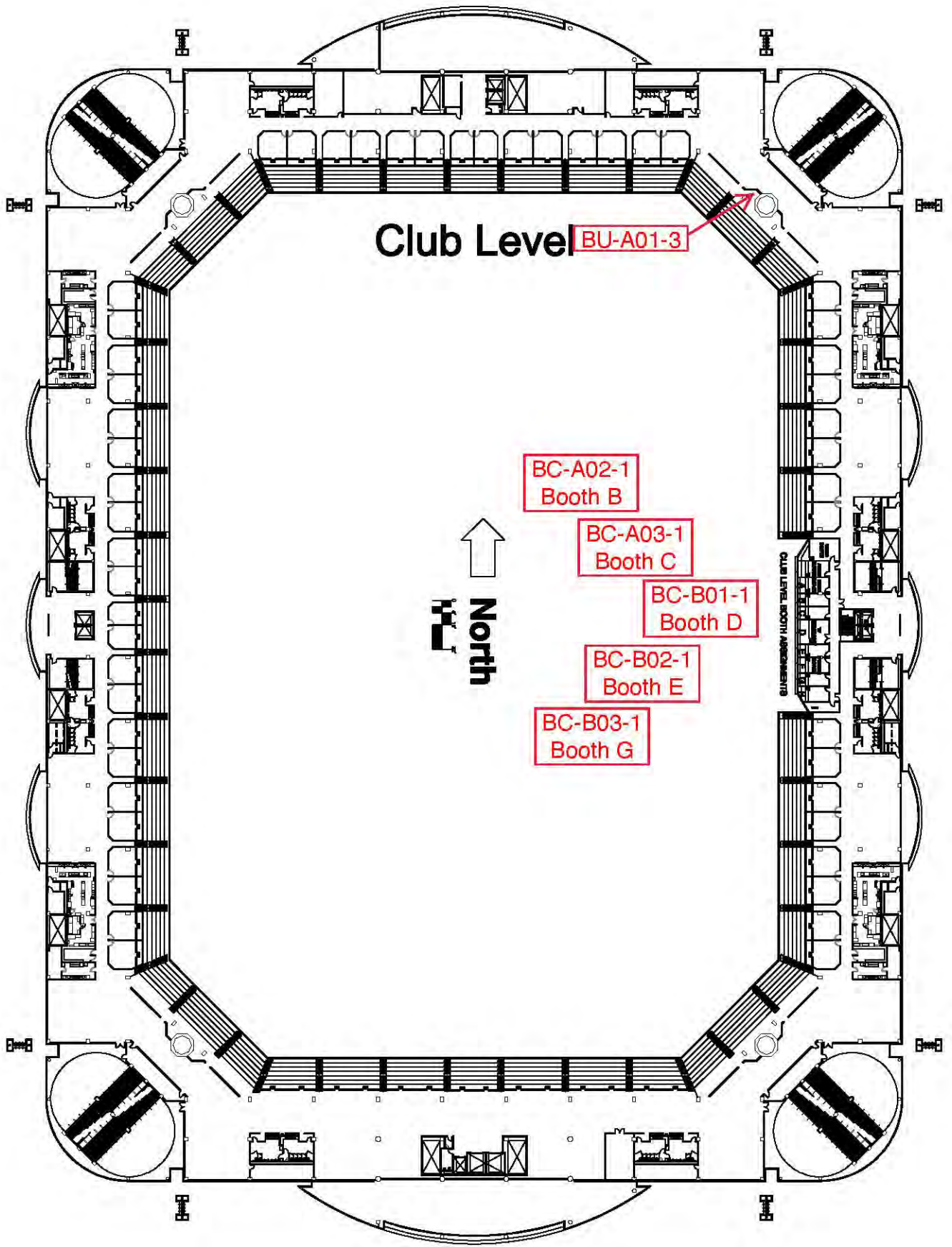

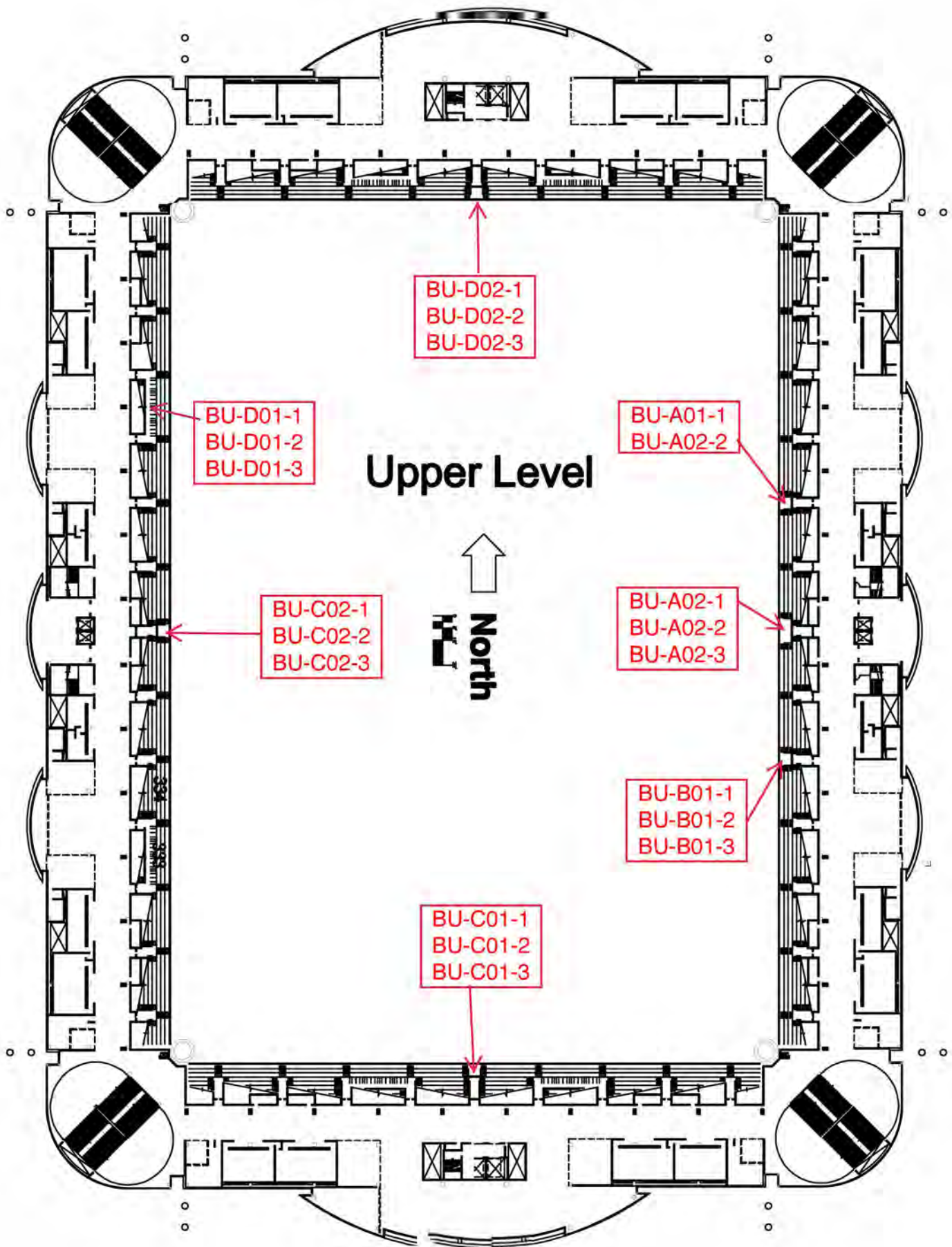

# Alamodome Fiber Boxes

## Field Level

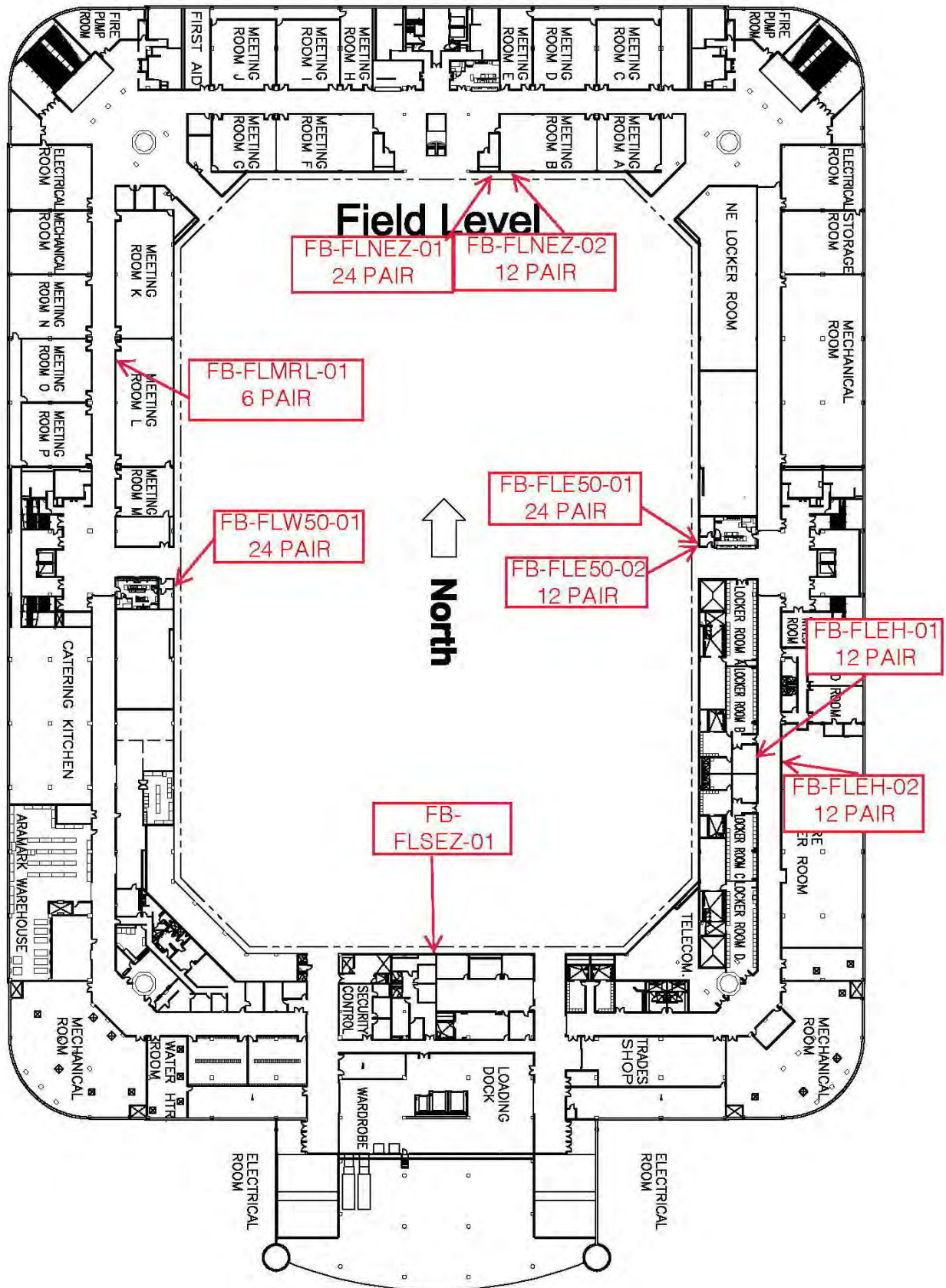

# Fiber Box - Field Level South End Zone 01

## MAP LOCATION



**FB-FLSEZ-01**  
**24 Strand Fiber**  
**To Truck Dock**  
**Fiber Box -A**  
**Row -1**



# Fiber Box- Field Level East Hallway 01 & 02

MAP LOCATION

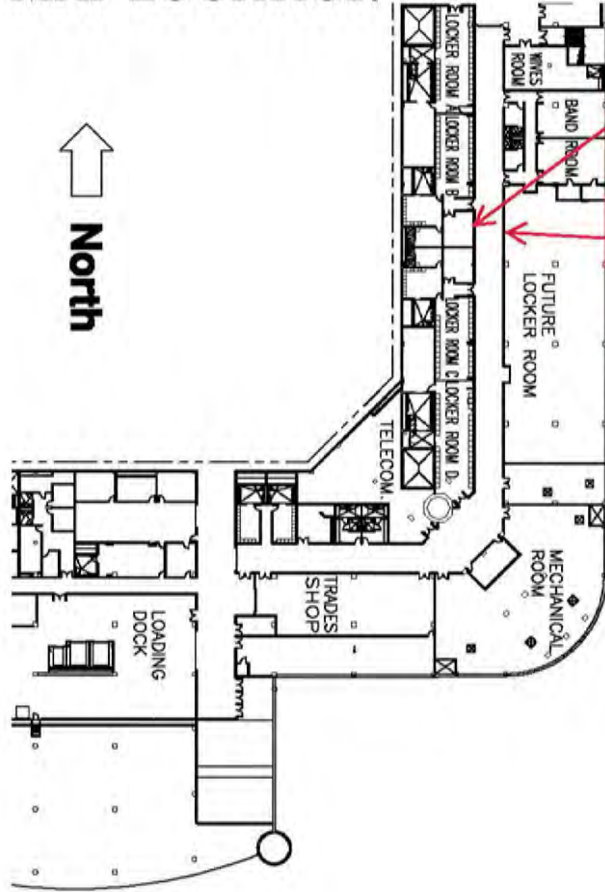

**FB-FLEH-01**  
12 Strand Fiber  
To Truck Dock  
Fiber Box - B  
Pannel - 3

**Locker Room B  
FB-FLEH-01**



**Home Team Locker Room  
FB-FLEH-02**

**FB-FLEH-02**  
12 Strand Fiber  
To Truck Dock  
Fiber Box -B  
Pannel - 3



# Fiber Box - Field Level East 50 01 & 02

## Map Location

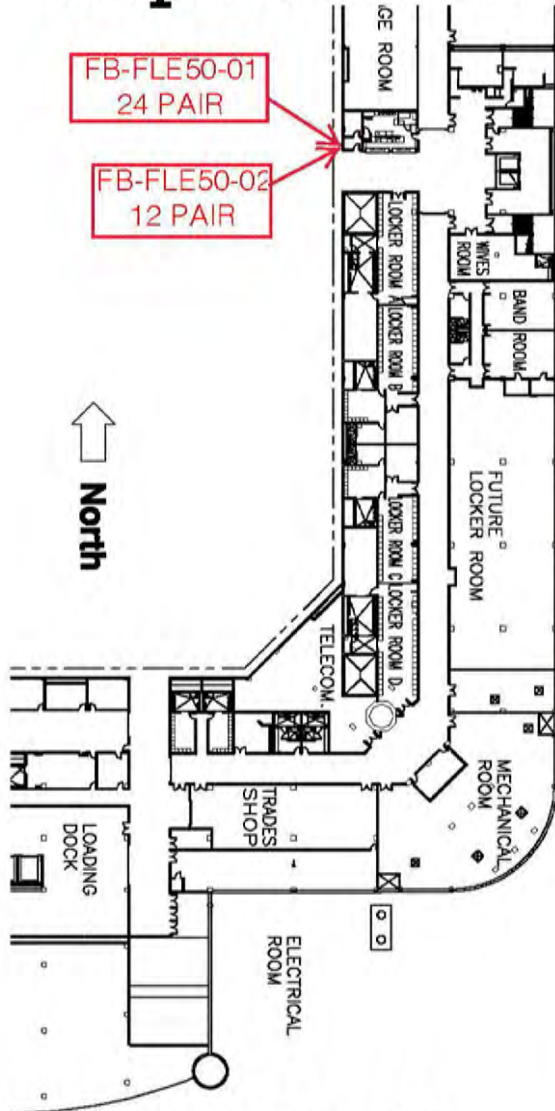

**FB-FLE50-01**  
24 Strand Fiber  
To Truck Dock  
Fiber Box - A  
Pannel - 1

**FB-FLE50-02**  
12 Strand Fiber  
To Truck Dock  
Fiber Box - B  
Pannel - 1

# Fiber Box - Field Level North End Zone 01 & 02

## Map Location

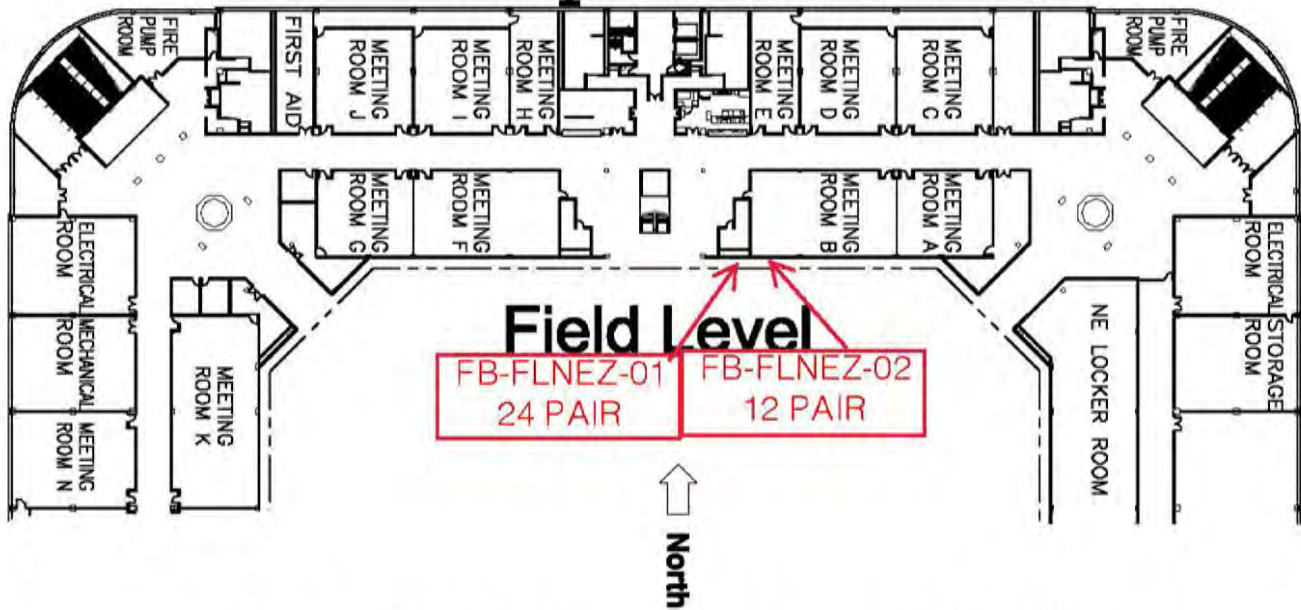

**FB-FLNEZ-01**  
24 Strand Fiber  
To Truck Dock  
Fiber Box - B  
Pannel - 3

**FB-FLNEZ-02**  
12 Strand Fiber  
To Truck Dock  
Fiber Box - B  
Pannel - 1

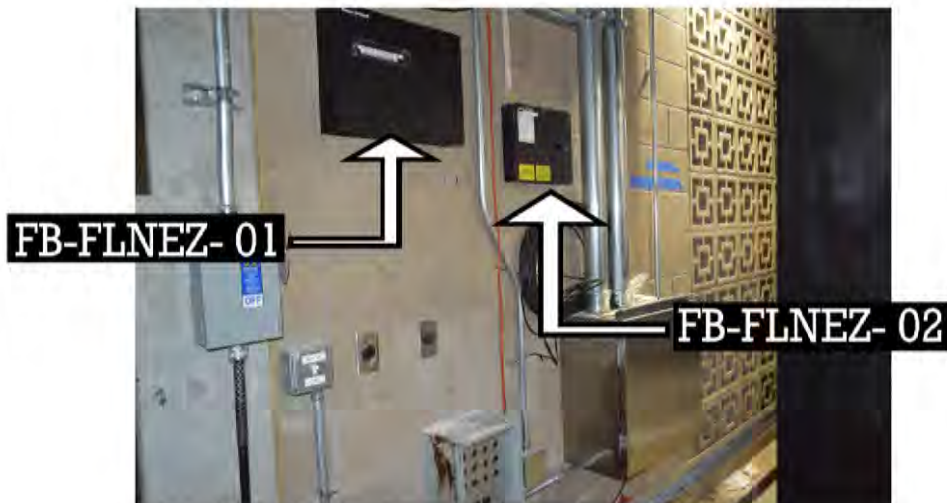



# Fiber Box - Field Level North West 01 Map Location

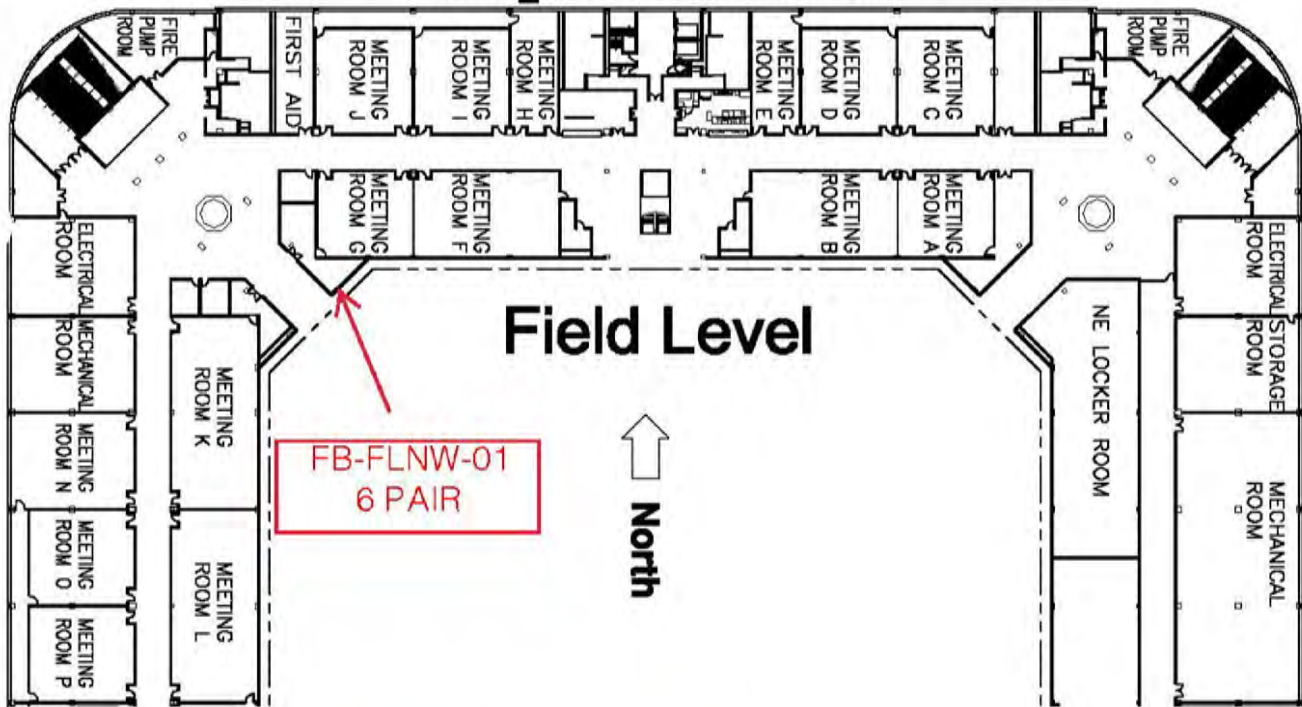

**FB-FLNW-01**  
**24 Strand Fiber**  
**To Truck Dock**  
**Fiber Box - B**  
**Pannel -1**

# Fiber Box- Field Level Meeting Room L 01 Map Location

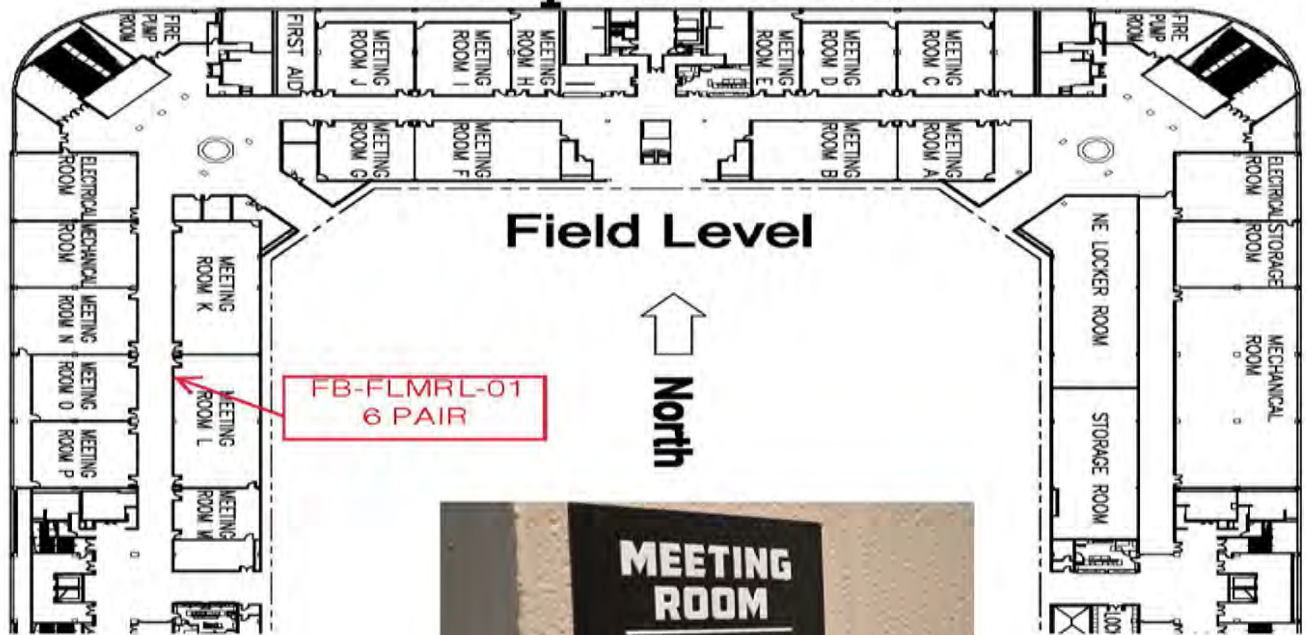

**FB-FLMR-01**

**FB-FLMRL-01  
6 Strand Fiber  
To Truck Dock  
Fiber Box - B  
Pannel - 1**

# Fiber Box - Field Level West 50 01

**\*Ladder Needed**



## MAP LOCATION

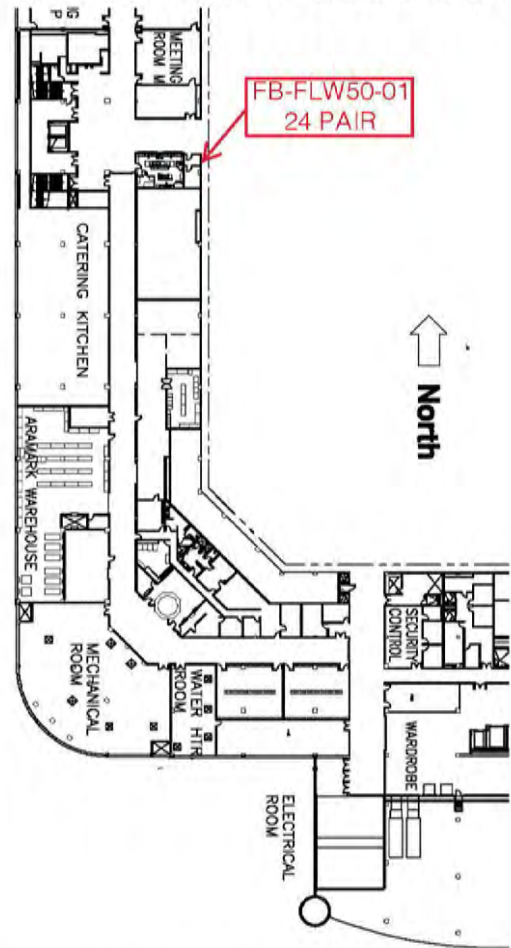

**FB-FLW50-01  
24 Strand Fiber  
To Truck Dock  
Fiber Box - A  
Pannel - 1**

# Club Level

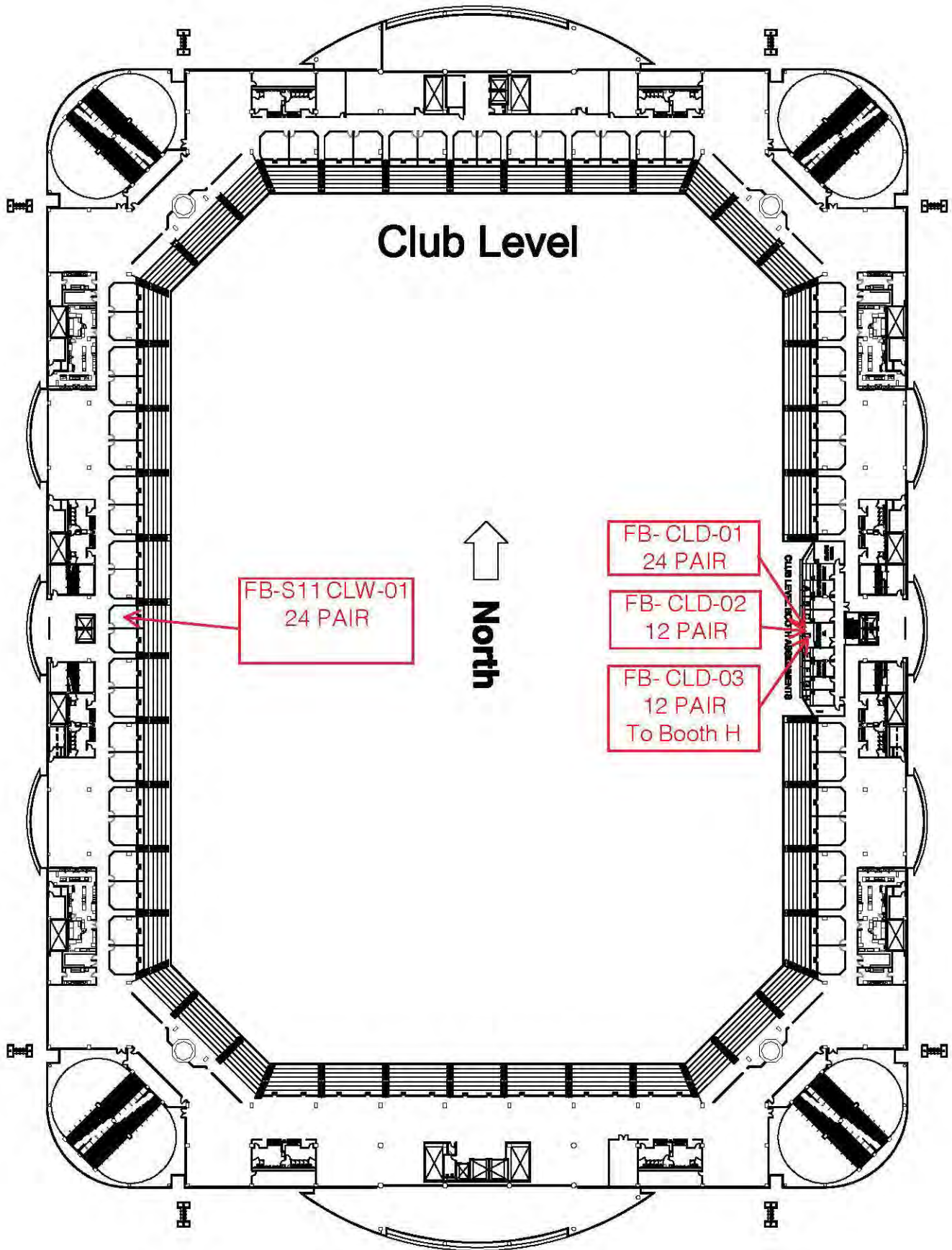

# Fiber Box - Club Level Booth D 01 & 02

## Map Location Broadcast Booths

FB-CLD-01  
24 Strand Fiber  
To Truck Dock  
Fiber Box - B  
Pannel - 1

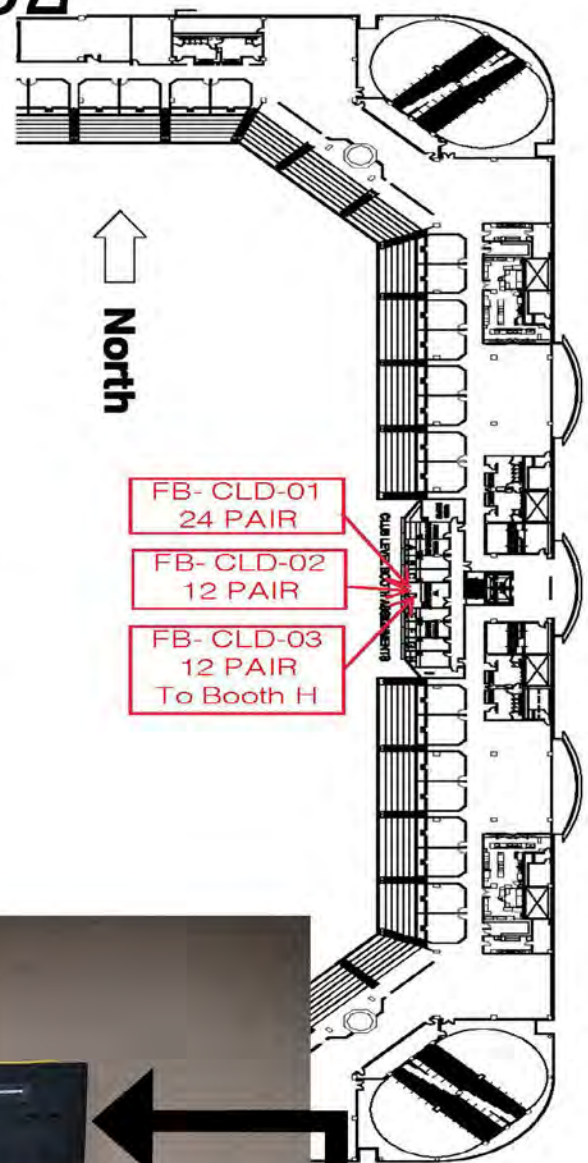

# Fiber Box - Club Level West 01

## Map Location Suite 11

FB-S11-CLW-01  
24 Strand Fiber  
To Truck Dock  
Fiber Box - B  
Pannel - 3

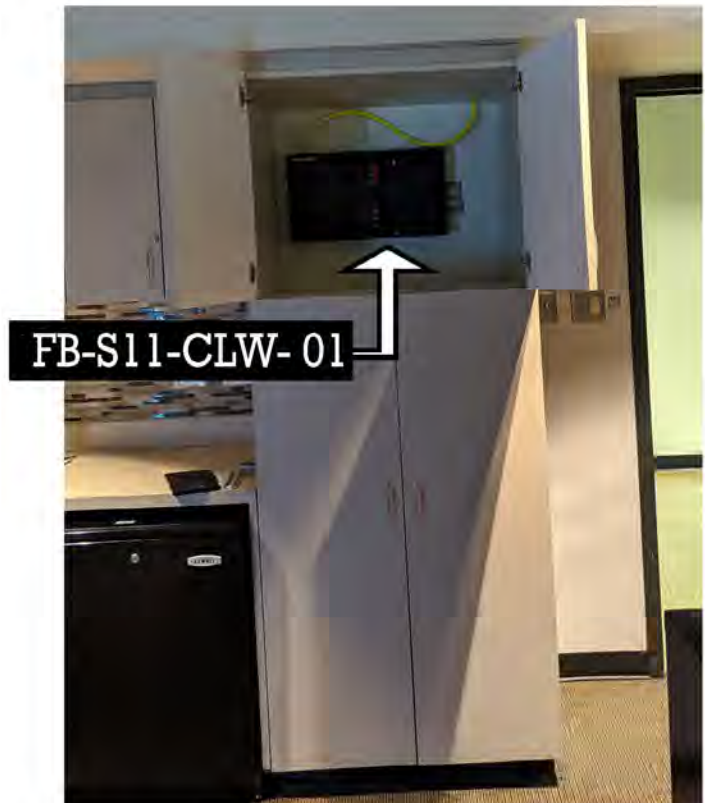
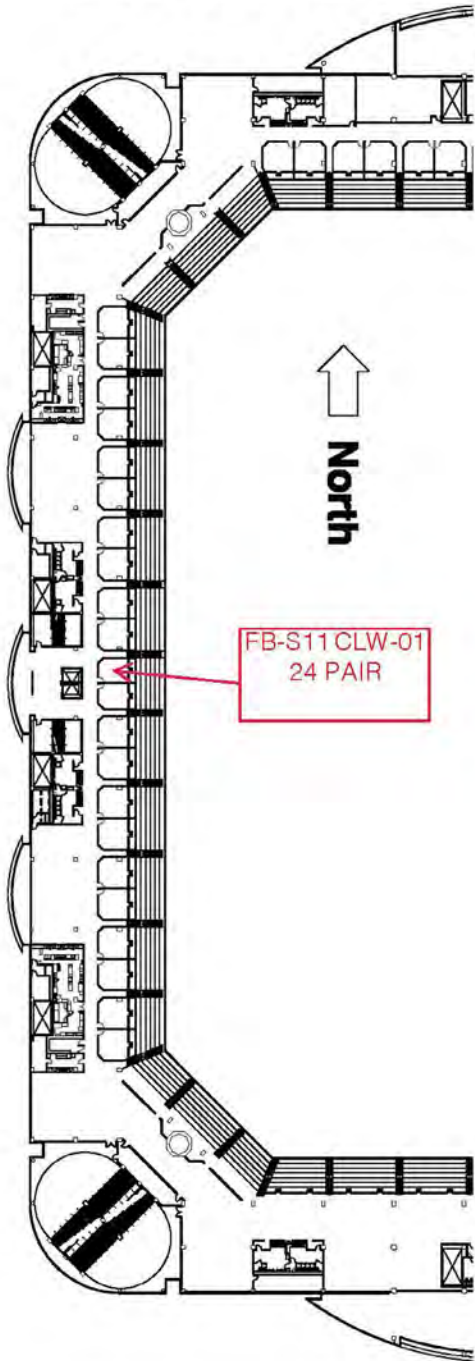

# Upper Level

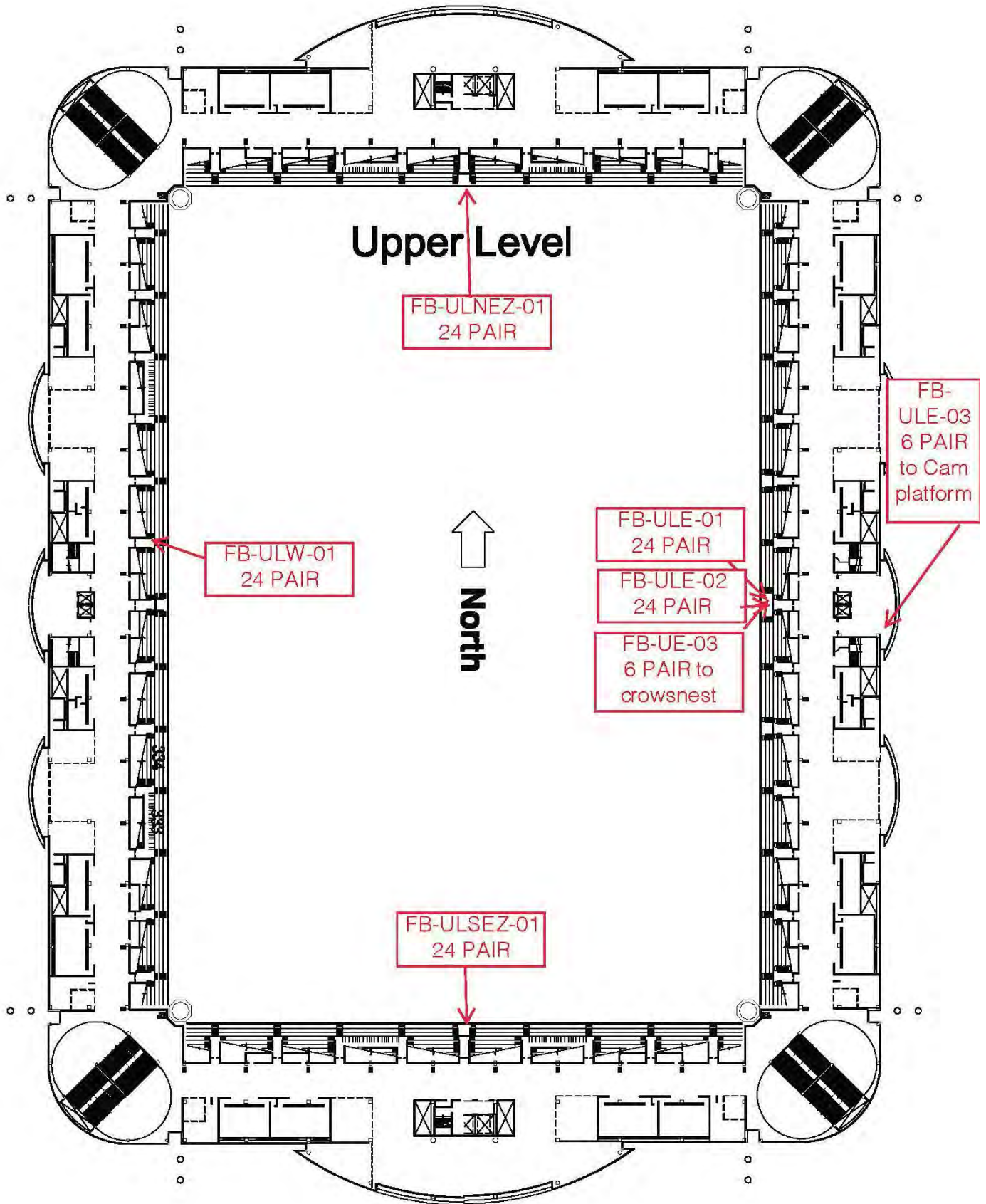

# Fiber Box - Upper Level South End Zone 01

## Map Location Sec. 325-324

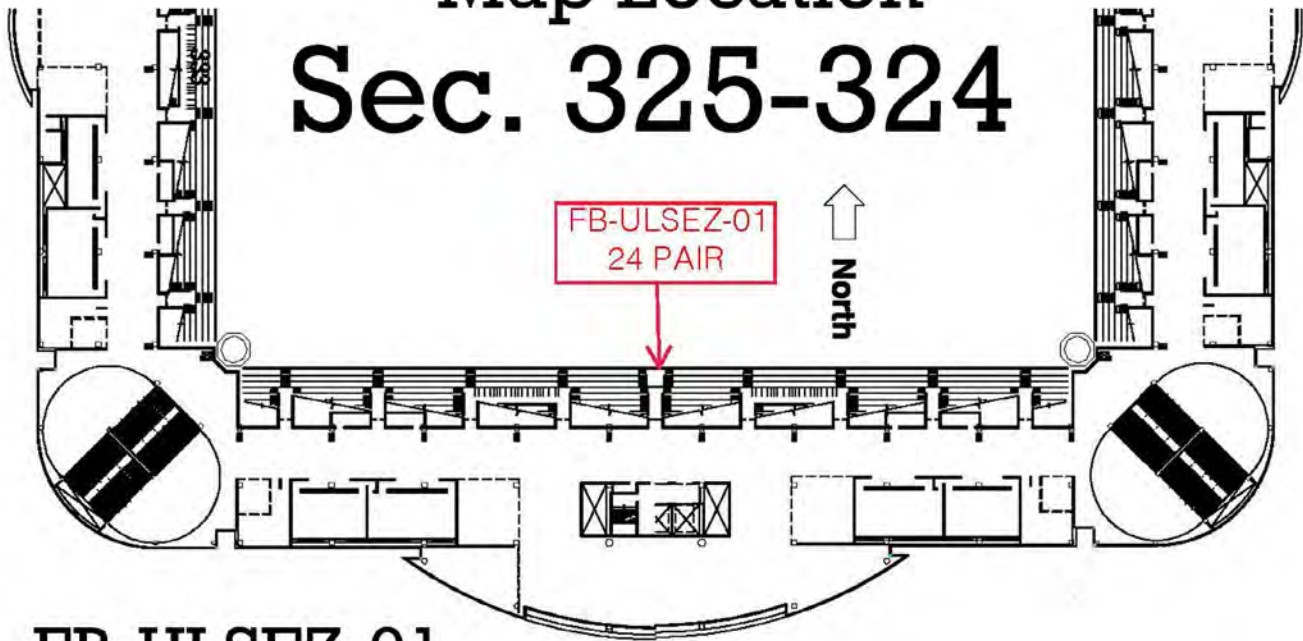

**FB-ULSEZ-01**  
24 Strand Fiber  
To Truck Dock  
Fiber Box - A  
Pannel - 3





# Fiber Box - Upper Level East 50 01 - 02 - 03

## Map Location Sec. 313-312

FB-ULE50-01  
24 Strand Fiber  
To Truck Dock  
Fiber Box - A  
Pannel - 2

FB-ULE50-02  
24 Strand Fiber  
To Truck Dock  
Fiber Box - A  
Pannel - 2

FB-ULE-01  
24 PAIR

FB-ULE-02  
24 PAIR

FB-UE-03  
6 PAIR to  
crowsnest

FB-  
ULE-03  
6 PAIR  
to Cam  
platform

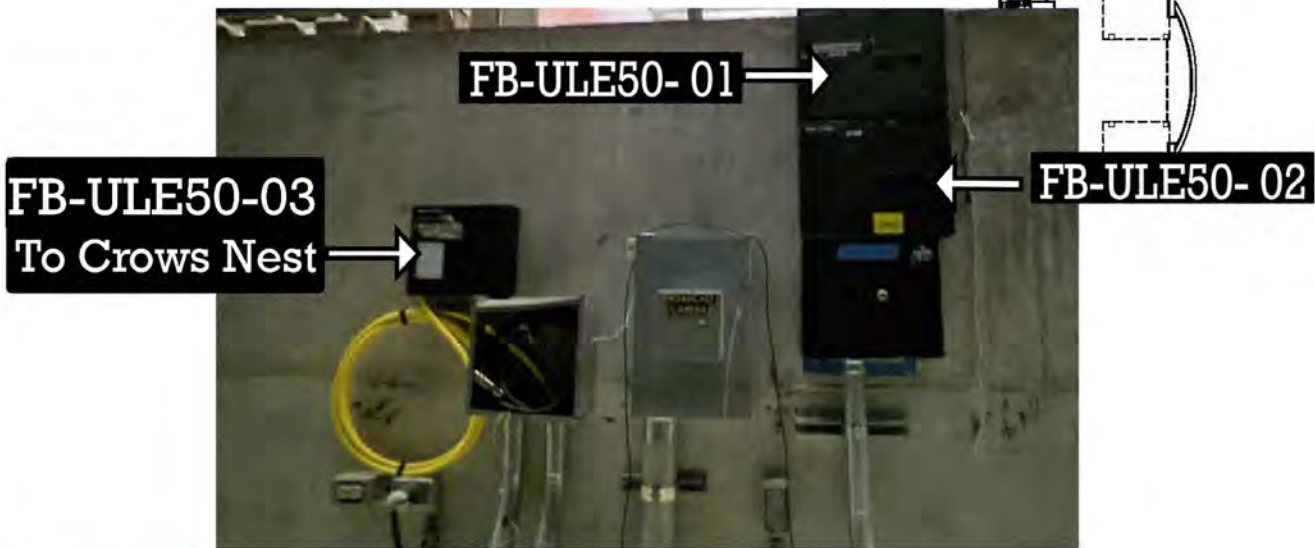
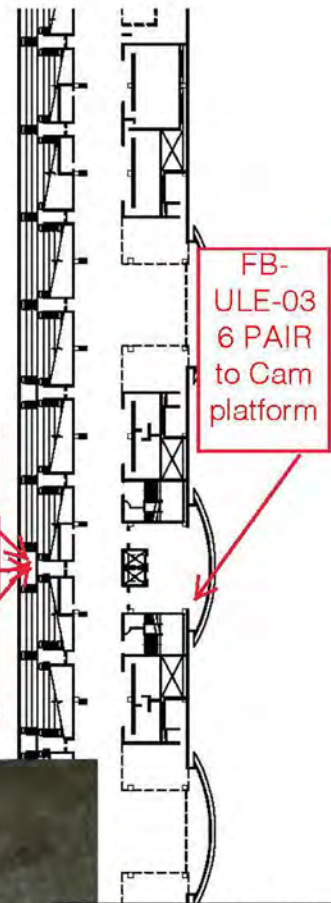

# Fiber Box - Upper Level North End Zone 01

## Map Location Sec. 301-348

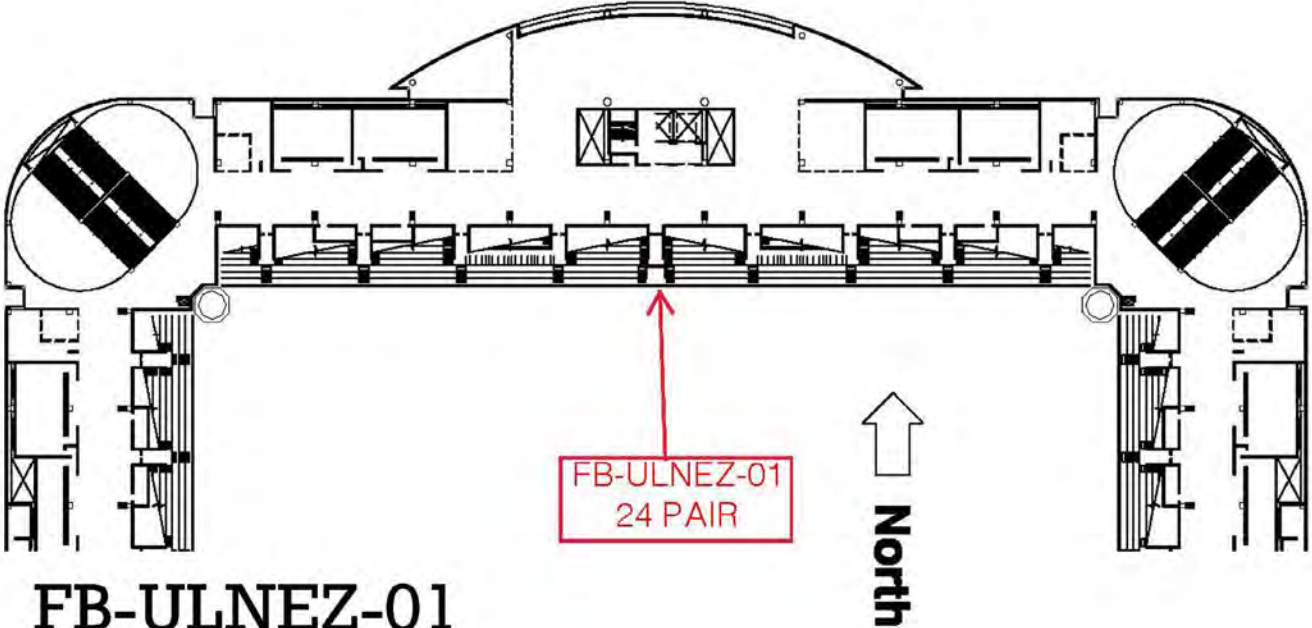

**FB-ULNEZ-01**  
**24 Strand Fiber**  
**To Truck Dock**  
**Fiber Box - A**  
**Pannel - 3**



# Fiber Box - Upper Level West 50 01

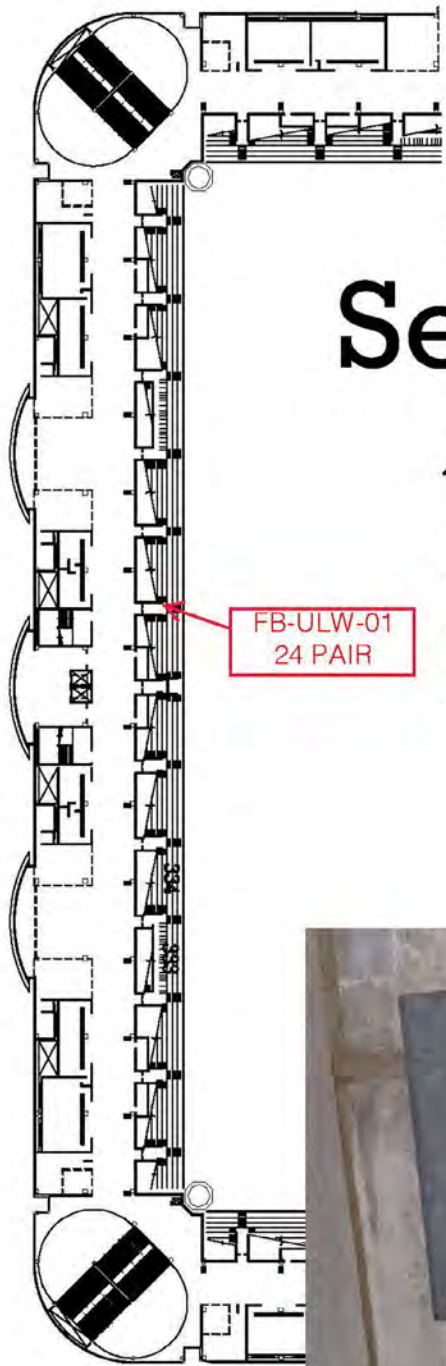

## Map Location Sec. 337-336



FB-ULW-01  
24 PAIR

FB-ULW50-01  
24 Strand Fiber  
To Truck Dock  
Fiber Box - A  
Pannel - 2

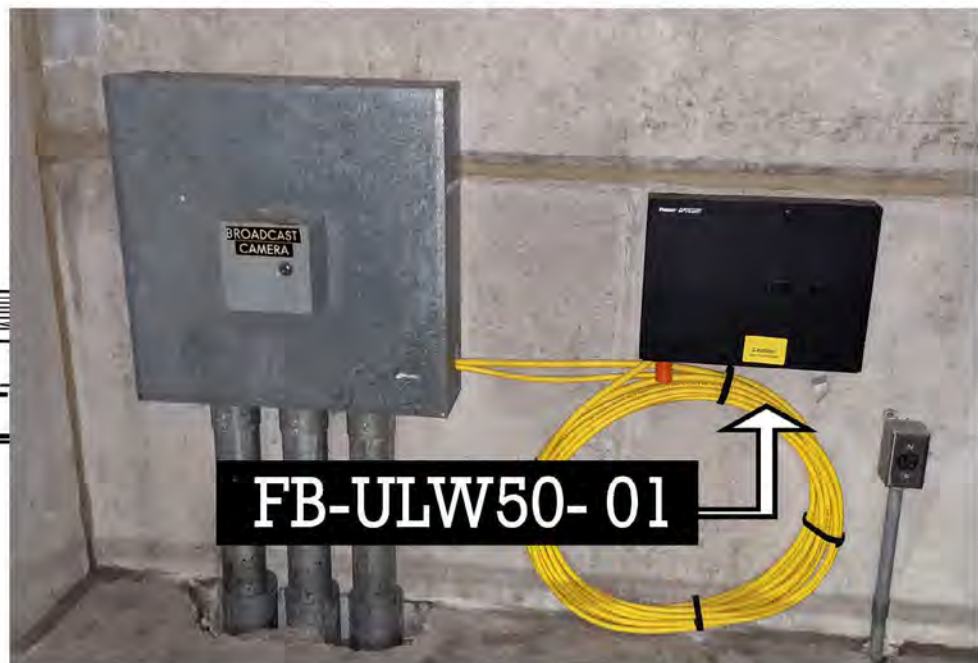

FB-ULW50-01



# Field Level - Restricted Areas

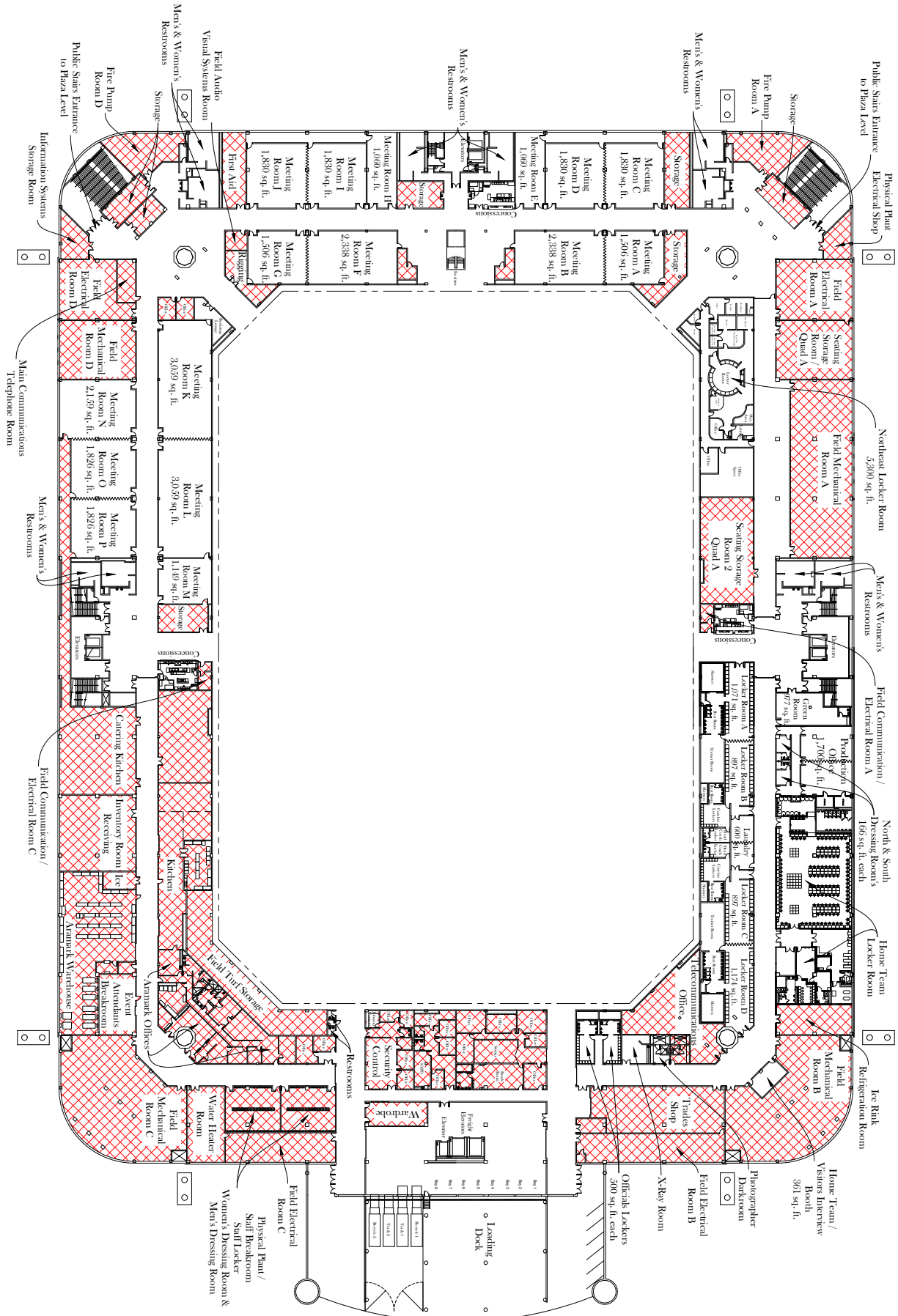

# Fire Safety Requirements

## **Pyrotechnics**

Licensee and all contractors must comply with the San Antonio Fire Department's Fire Regulations for Public Assembly Occupancies. A permit is required for the use of pyrotechnics during events. Please contact Jose A. Rios with SAFD by phone, (210) 207-3695, or by email at [Joe.Rios@sanantonio.gov](mailto:Joe.Rios@sanantonio.gov) for permitting inquiries.

## **Automobiles**

Personally-Owned Vehicles (POV's) may not be driven into the facility without permission from your Event Coordinator and may only be operated inside the building for loading and unloading of large equipment. Vehicles may be displayed with prior approval from the City of San Antonio Fire Marshal.

It is the responsibility of the Licensee to ensure that exhibitors are aware of these guidelines.

## **Floor Plans**

The Alamodome and San Antonio Fire Marshals must approve all seating prior to on sale. The blocking of aisles, exits or corridors of any type is prohibited.

## **Electrical Wiring**

Electrical cords will be grounded and UL listed. Extension cords may be used provided they are plugged directly into an outlet or an approved power strip and are rated for the intended power use.

## **Standby Inspector**

If determined necessary by the San Antonio Fire Department, a standby fire marshal will be present during the event. Any costs for this additional requirement will be the responsibility of the promoter.

## **Indoor Structures and Enclosed Tenting**

All Indoor enclosed structures are required to have operational smoke detectors and fire extinguishers. All structures are subject to approval by the fire marshal.

# Permitting

The Development Services Department for the City of San Antonio has outlined the following process for permitting. Items possibly needing permitting include but are not limited to generators, tents and stages. Please contact the Development Services Department to ensure you complete proper permitting.

Jeremy Camarillo  
Development Services Manager  
(210) 207-0003  
Jeremy.Camarillo@sanantonio.gov

## **The following items should be submitted to the above contact:**

### 1. Temporary Use Application:

a. <https://docsonline.sanantonio.gov/FileUploads/DSD/TemporaryUsesApplication.pdf>

### 2. Please provide two hard copies of the site plan of the event

- a. Identify all tents
- b. Identify all stages/temporary event structures
- c. Identify location of generators

### 3. A city registered Texas Master Electrician will need to secure an electrical permit for the generators

a. [https://docsonline.sanantonio.gov/FileUploads/DSD/DSD\\_Electrical\\_Application.pdf](https://docsonline.sanantonio.gov/FileUploads/DSD/DSD_Electrical_Application.pdf)

### 4. Please provide total square footage, number of stories, occupant load, floor plan for

- a. All tents
- b. All stages/temporary event structures

### 5. Please confirm that a safety and traffic plan have been put into place

### 6. Please provide two hard copies of the Texas engineered drawings, specs, fire rating fabric certificate, and anchoring details for tents over 5,000 sq. ft. (two hard copies)

### 7. Please provide two hard copies of the Texas engineered drawings, specs, and bracing details for temporary event structures (Stages, scaffolding, rigging, platforms, and visual effect structures over 400 sq. ft.)

### 8. Inspections will include Building, Fire, and Electrical

- a. Building will require a third party inspection report in addition to CoSA building inspection for any items outlined in bullet points 5 & 6



# LABOR RATE CARD

<b>PUBLIC SAFETY (per hour)</b>			
Security Manager	\$37.50	SAPD Supervisor (3 Hours Min.)*	\$70.13 / \$55.13
Security Supervisor	\$29.00	SAPD Sup. (3 Hr. Min.)* <b>Effective 4/1/24</b>	\$72.01 / \$57.01
Security Guard	\$26.00	SAPD Officer (3 Hours Min.)*	\$59.00 / \$44.80
In-House Security Officer	\$22.50	SAPD Off. (3 Hr. Min.)* <b>Effective 4/1/24</b>	\$61.31 / \$46.31
Medical Services ALS/BLS*	\$63.10 / \$55.07	SAFD	\$82.40
Ambulance/ Mulebulance (per hr.)	\$149.35/ \$86.05		
<b>* Higher rate applies to first hour of service with lower rate being applied to all hours there after.</b>			
<b>EVENT SERVICES (per hour)</b>			
Event Supervisor	\$65.00	Guest Service Manager	\$28.00
Event Coordinator	\$50.00	Guest Service Attendant	\$25.00
<b>BOX OFFICE (per hour)</b>			
Rental Fee	\$500.00/day	Box Office Manager	\$50.00
Security Deposit	\$500.00/use	Box Office Supervisor	\$35.00
Box Office Manager (Off-site)	\$60.00	Ticket Seller	\$25.00
<i>* Also applies to HBGCC and Carver Community Center</i>			
<b>OPERATIONS AND MAINTENANCE (per hour)</b>			
Operations Supervisor	\$50.00	Head Turf Manager	\$50.00
Operations Staff	\$35.00	Equipment Operator	\$35.00
HVAC System Operator	\$50.00	Electrician	\$50.00
Plumber	\$50.00		
<b>OTHER (per hour)</b>			
Parking Supervisor	\$35.00	Cleaning Supervisor	\$35.00
Parking Attendant	\$25.00	Cleaning Attendant	\$29.00
<b>A/V AND TELECOMMUNICATIONS EQUIPMENT &amp; SERVICES (per unit/per event)*</b>			
<b>A/V SERVICES AND EQUIPMENT RATES *AR = Advanced Rate; SR = Show Rate</b>			
In House Closed Circuit Monitors	\$600.00	Additional Closed Circuit Channel	\$100.00
60" Zenith Color Television	\$350.00		
<i>Rate Card continues to next page...</i>			





# EQUIPMENT RATE CARD

<b>A/V AND TELECOMMUNICATIONS EQUIPMENT &amp; SERVICES (Continued)</b>			
<b>BROADCAST SUPPORT</b>			
Camera Hookup – Triax	\$195.00	Fiber Connectivity	\$370.00
ENG Hookup – 1 Video, 2 Audio	\$120.00	Fiber Connectivity to Transmission Carrier	\$75.00
Audio/Video Interconnectivity	\$185.00	House Light Operator	\$30.00
<b>CATV/DMX SERVICES</b>			
Cable Television	\$150.00		
<b>INTERCOM</b>			
Wired Intercom	\$50.00	Wireless Intercom	\$75.00
<b>MICROPHONES &amp; DIRECT BOXES</b>			
Basic Mic. with Cable & Stand	\$25.00	Wireless Headset Mic (must include wireless system direct box)	\$25.00
Wireless Mic System	\$75.00		
<b>MISCELLANEOUS</b>			
Park and Power	\$250.00/Truck		
<b>P. A. PACKAGES</b>			
Small (8 channel power mixes, 2ea. speakers w/stands, 2ea. wired mics w/stands and all cables)	\$350.00	Medium (8 channel power mixes, 4ea. speakers w/stands, 4ea. wired mics w/stands and all cables)	\$500.00
Large (16 channel mixer, 2ea. large speakers w/stands, 2ea. floor monitors, 1 ea. stereo amplifier, 6ea. wired mics w/stands and all cables)	\$1,000.00	Active Press Box (16 channel 12M/4L)	\$60.00
Arena (3-way EV system hung around Jumbotron)	\$2,000.00	Stadium (16 EV Horns Center Hung)	\$2,000.00
Audio patch Fee	\$30.00	Audio Snake Box and Fan - Out (100' – 12 channels)	\$50.00
Single Analog Line	\$250.00	Com Drop	\$20.00
Digital Multi-Service Line 2-Lines	\$275.00	Ringdown with Instruments	\$250.00
Additional Lines on Multi Line Service	\$35.00	Dedicated T1 Line	By Quote
Dry Pair Connection – SBC D Marc	\$200.00	Dry Pair Connection – Internal	\$100.00
Voice Mail	\$15.00	Telephone Technician Services	\$90.00/hour
Long Distance Restriction per line	\$5.00	Dedicated Internet Line	\$950.00
Video Pass Through	By Quote	Video Production	By Quote
360 VIDEO RING	\$3,600.00	In Stadium Sound System	\$3,600.00
HD VIDEO Walls (4)	\$1,250.00/each	Domestic Long Distance per minute	\$0.40
Temp Phone (De-) Activation	\$15.00		

*Rate Card continues to next page...*



# EQUIPMENT RATE CARD

EQUIPMENT RENTAL (per unit/per event)			
Basketball Floor	By Quote	Pipe & Drape	\$25.00
8' Bike Rack	\$25.00	Podium	\$35.00
Camera Platform	\$400.00	Project Screen	\$35.00
Chairs	\$2.50	Riser	\$45.00
Chrome Stanchion	\$25.00	Shore Power	\$200.00
Dry Erase Board	\$25.00	Sports Turf	By Quote
Easel	\$25.00	Spotlight ( Zenon Gladiator 3)	\$200.00
Extension Cord	\$25.00	Stage (60' x 40')	\$3,500.00
Forklift (6 Ton)	\$300.00	Table (8' x 30")	\$15.00
Ice Floor	By Quote	Table (8' x 18")	\$15.00
Inertia Barricade	\$2,000.00	Table Dolly	\$20.00
Lost Room Key	\$100.00	Yellow Jacket Cable Ramp	\$25.00

Published rates are subject to change. To confirm current costs, please contact Alamodome Booking:  
 Phone; (210) 207-3752 • Email; Toryn.Jones@sanantonio.gov • Online form; www.alamodome.com



SAN ANTONIO  
**ALAMODOME**

---

**ONE TEAM**



**100 MONTANA ST. SAN ANTONIO, TEXAS 78203**